

FIRST ANGLE PROJECTION

REMOVE ALL BURRS AND SHARP EDGES

ISSUE	REVISION	MOD No.	DATE
A	FIRST ISSUE	13060	2-Feb-11

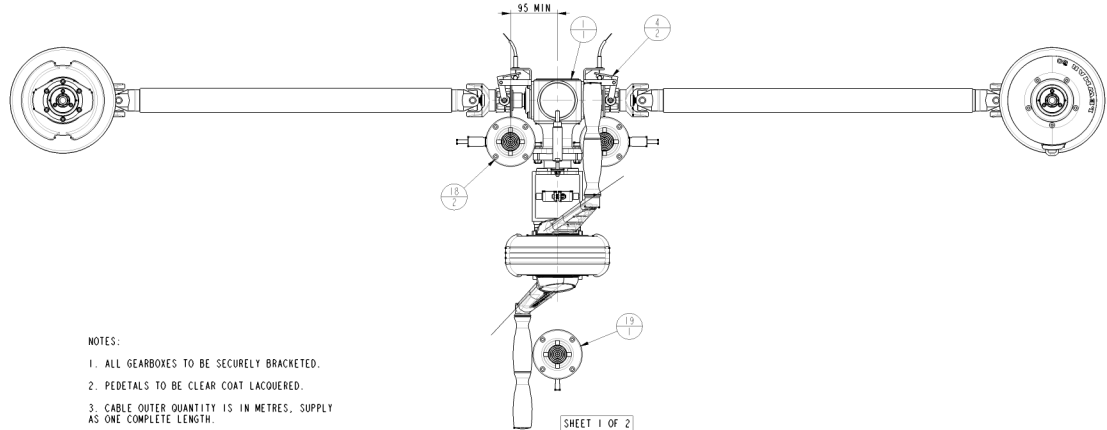
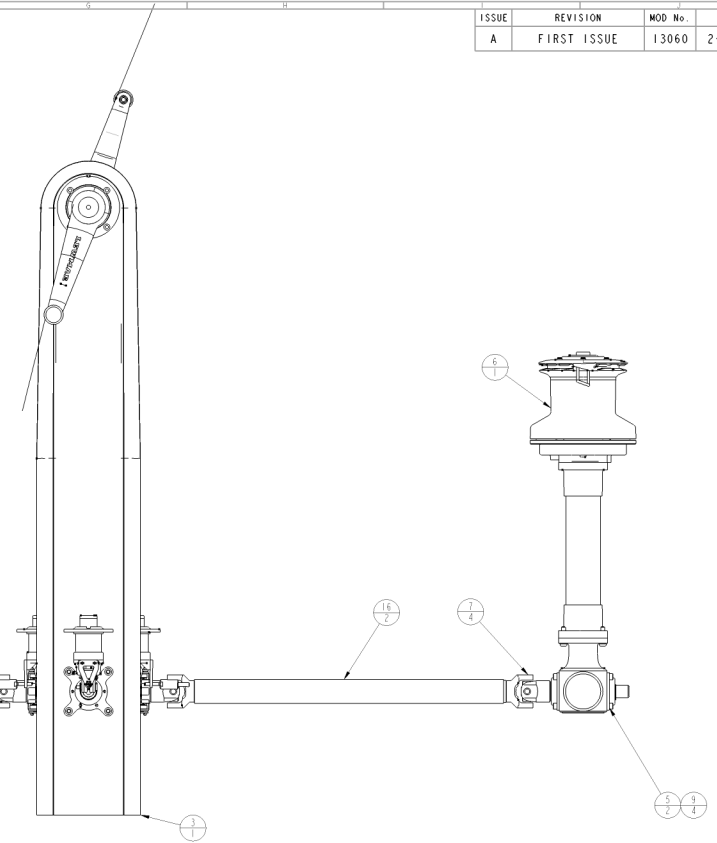
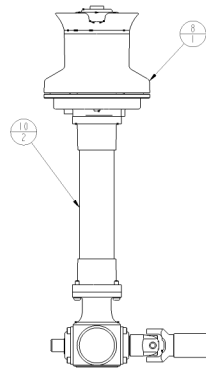
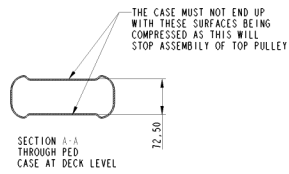
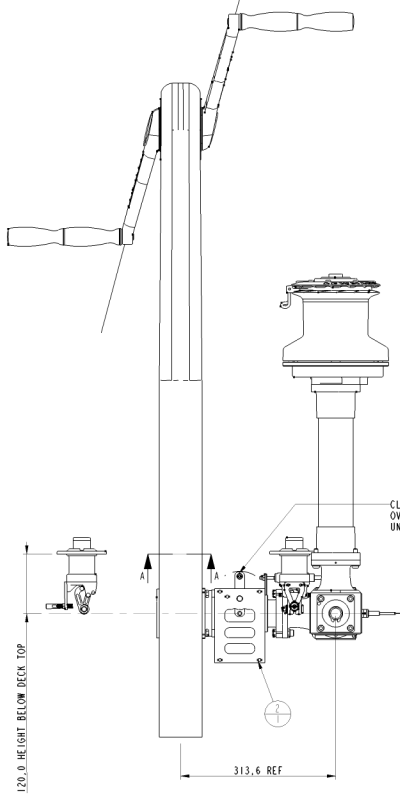

- NOTES:
1. ALL GEARBOXES TO BE SECURELY BRACKETED.
  2. PEDETALS TO BE CLEAR COAT LACQUERED.
  3. CABLE OUTER QUANTITY IS IN METRES. SUPPLY AS ONE COMPLETE LENGTH.

21	49050050	50ASTOR BK AL WINCH	7,870	15,740	2
20	49048050	48 ASTOR WINCH	5,950	11,850	3
19	40100233	FS MK3 (ODBOX) YELLOW BUTTON	0,510	0,510	1
18	40100219	FOOT SWITCH MK3 + LM	0,510	1,020	2
17	b8737	PACKING CRATE	N/A	N/A	1
16	40006337	CARBON DRIVE SHAFT (2m)	0,840	1,680	2
15	b2648	HY SOL XEA 9359.3 ADHESIVE	N/A	N/A	1
14	b2283	CABLE OUTER	N/A	N/A	6
13	b2284	INNER WIRE	N/A	N/A	3
12	b2089	CIRCLIP	N/A	N/A	5
11	40003229	SPLINED SHAFT END	0,075	0,300	4
10	40004426	SPACER TUBE	1,280	2,560	2
9	40002270	CONNECTING SHAFT	0,060	0,240	4
8	49060006	60/3GPST BK WINCH ASSEMBLY	8,000	8,000	1
7	40100405	UNIVERSAL COUPLING	0,534	2,136	4
6	49060000	60/3GPST BK WINCH ASSEMBLY	8,000	8,000	1
5	40100005	4 MAN BEVEL BOX	2,350	4,700	2
4	40100214	INTEGRATED CLUTCH ASSY	0,750	1,500	2
3	40100145	STRAIGHT PED. 976 CTRS. FARR 400	6,600	6,600	1
2	40100314	OD BOX. 1 BEAM PED MOUNT 1-1.8	3,750	3,750	1
1	40100007	4 MAN B/BOX (TWIN CLUTCH SHAFT)	2,750	2,750	1
ITEM	PART No.	DESCRIPTION	INDIV PART WEIGHT Kg	COMBINED PART WEIGHT Kg	QTY
ESTIMATED TOTAL SYSTEM WEIGHT			77,336 Kg		

SHEET 1 OF 2

MATERIAL SEE BOM	ALL DIMENSIONS IN mm TOLERANCES (UNLESS STATED) LINEAR ± ANGULAR ±	DRW RFIELDS DATE 2-Feb-11	TITLE PCT40 WINCH SYSTEM
FINISH N/A	SCALE 1:5	PART No. 40200062	LEWIS
MODEL NAME: 40200062			

PART No.  
40200062

ORIGINAL SIZE A1  
0 10 20 30 40 50  
REFERENCE SCALE IN MM

Manufactured and assembled in accordance with the specifications in issue at the date of publication.

FIRST ANGLE PROJECTION

REMOVE ALL BURRS AND SHARP EDGES

ISSUE	REVISION	MOD No.	DATE
01	FIRST ISSUE	13060	2-Feb-11

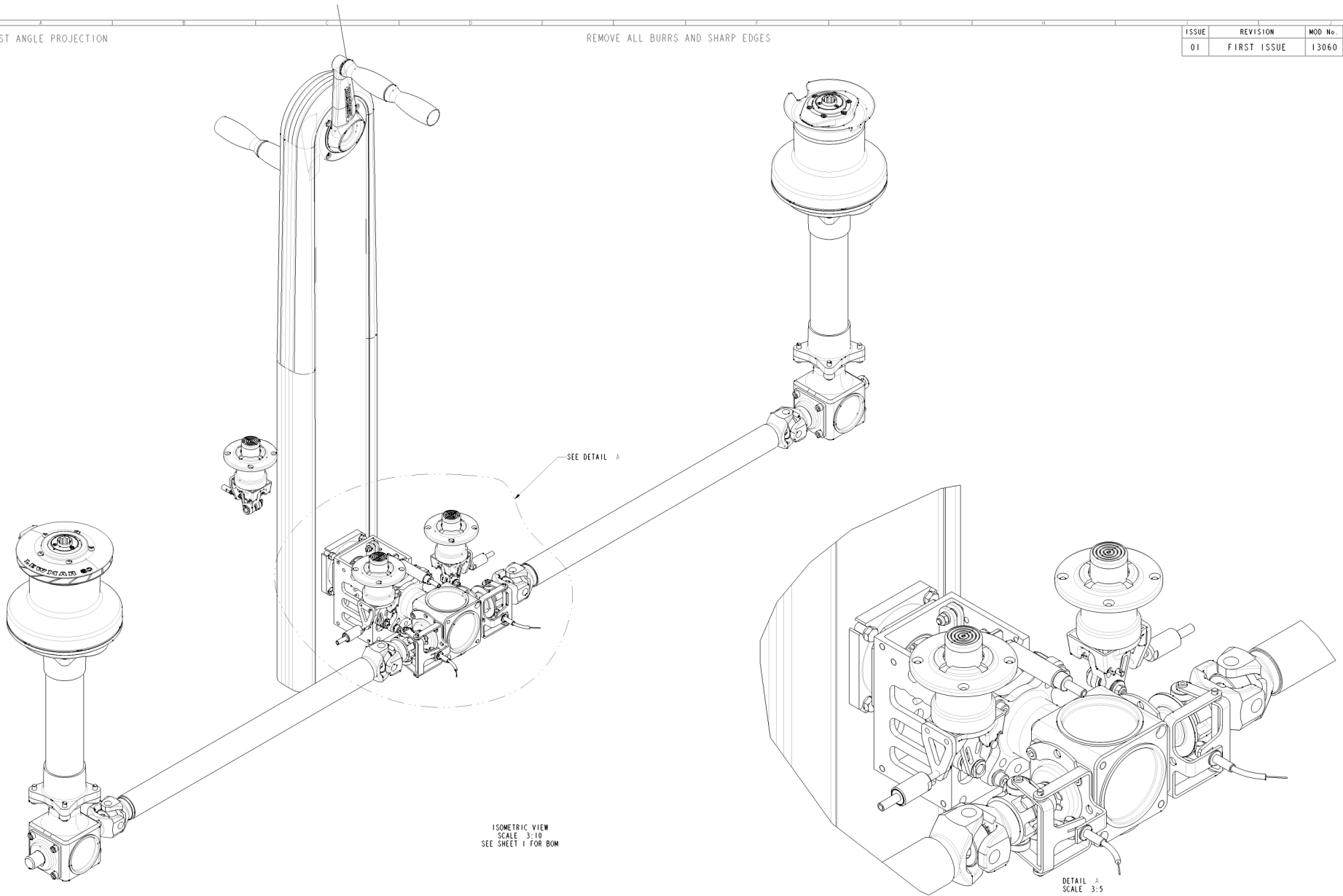

ISOMETRIC VIEW  
SCALE 3:10  
SEE SHEET 1 FOR BOM

DETAIL A  
SCALE 3:5

PART No. 40200062



Unauthorized use, manufacture or reproduction  
in whole or in part is prohibited.

SHEET 2 OF 2

MATERIAL SEE BOM	ALL DIMENSIONS IN mm TOLERANCES (UNLESS STATED) LINEAR ± ANGULAR ±	DRN RFIELDS DATE 2-Feb-11	TITLE PCT40 WINCH SYSTEM
FINISH N/A	MODEL NAME: 40200062	SCALE 1:1	PART No. 40200062

LEWIS & CLARK