

B&G

H 3000

www.bandg.com

CONTENTS

B&G

Notification.....	7
Liability and Safety Warnings.....	8
About B&G.....	9
About this Handbook.....	9

SYSTEM INTRODUCTION

H3000 System Example.....	11
H3000 Pilot ACP.....	12
Graphical Pilot Display (GPD).....	13
Hand-Held Controller.....	14
Joystick.....	15
Man Overboard Button.....	16

OPERATING INFORMATION

Switching On.....	20
-------------------	----

GETTING STARTED

Graphic display (GPD) Keys Explained.....	21
GPD Menu Structure.....	24

GPD MAIN MENU

Timer.....	27
Pilot.....	27
Instruments.....	30
GPS.....	32
Trip Control.....	33
Remote Units.....	34
Setup.....	35
Alarms.....	35
Calibration.....	37
Compass Calibration.....	37
Halcyon 2000 Compass Calibration.....	38
Halcyon Gyro Compass Calibration and Setup.....	39
Heading Source Selection.....	40
Damping.....	40
Dynamic Damping.....	40
This Display.....	42
Page Setup.....	42
Screen.....	43

Show Alarms on this Display	43
Favourites	44
Units.....	45
Unit Information.....	46
Key Lock	46
Commission.....	46
Use SOG as Speed Input	46
Heading.....	47
Pilot.....	47
System	48

PILOT OPERATION

Engaging the Pilot	49
Dis-Engaging the Pilot	49
Changing the Pilot Course.....	49
Pilot Mode Selection	50
Steer to Compass	50
Steer to Apparent Wind Angle	51
Steer to True Wind Angle	51
Steer to Waypoint	51
Steer to Target TWA	53
Power	53
Response Mode	54
Response Mode: Halcyon Gyro-Stabilised Compass	54
Response Mode: Halcyon 2000 Compass or Other Sources	54
Action.....	55

COMMISSIONING

Pilot Installation Check List.....	60
Drive Unit and Steering System	60
Hydraulic Rams	60
Hydraulic Pumps	61
Rotary Drives.....	61
Compass Installation.....	62
Electronics Installation	62
Parameters to be Set	63
Pilot Commission	64
Dockside Setup.....	64
Sea Trial.....	68
Checking Rudder Gain Learning.....	69
Setting the Rudder Gain Manually	69
Setting the Rudder Gain Value	70

Checking the Boat Lag	71
Boat Lag Response	71
Setting the Boat Lag Value	72
Advanced Settings	72
Speed Source	73
Automatic Response	73
Recovery Mode	74
Nav Source	75
Magnetic Dip Zone	76
Pilot Speed Cal	77
Setting the Speed Calibration Value	78
Joystick Type	78
Boat Length	79
Rudder Max Angle	79
Watch Alarm Lock	79

INSTALLATION INFORMATION

Cable and Connection Information	80
General Wiring Notes	80
Pilot Drive Unit Cables	81
Network Installation	82
Pilot Display Connections	84
ACP Unit Terminal Details	85
Clutch Voltage Selection	86
DIP Switch Location	87
ACP Wiring Connections	88
Network & Alarm	88
Man Overboard Button & Hand-held Controller	89
Remote Button & Joystick	90
Hydraulic Ram Drives	91
Rotary Drives	92
Stern Drives	93
Proportional Solenoid	94
Continuous Drives	95
Linear Feedback	96
Halcyon 2000 Compass	97
Halcyon Gyro Stabilised Compass	98
Direct Speed Input	99
Direct Speed Input	100
Rotary Rudder Reference Sensor	101
Installation of RRF	101
Typical System with Tiller Arm and Quadrant	102

Steering System Orientation..... 103
RRF Position..... 104
Drag-Link & RRF Position..... 104
Linear Feed Back Unit..... 105

Diagnostic Data

Fault Diagnosis..... 107

B&G

NOTIFICATION

The information contained in this document is subject to change without prior notice.

Navico UK Ltd. shall not be liable for errors contained herein or for incidental or consequential damages in connection with the furnishing, performance or use of this document.

No part of this work covered by the copyright hereon may be reproduced or otherwise copied without prior permission from Navico UK Ltd.

© 2008 Navico UK Ltd. All rights reserved.

Navico UK Ltd.
Premier Way, Abbey Park,
Romsey, SO51 9DH,
United Kingdom

Tel: +44 1794 518448
Fax: +44 1794 518077
www.bandg.com
email: sales@bandg.com
email: support@bandg.com

LIABILITY AND SAFETY WARNINGS

Navico UK Limited accept no responsibility for the use and/or operation of this equipment. It is the user's responsibility to ensure that under all circumstances the equipment is used for the purposes for which it has been designed.

Warning: Electrical Hazard

This equipment uses high voltage electrical power. Contact with high voltages may result in injury and/or loss of life.

Warning: Calibration

The safe operation of this equipment is dependent on accurate and correct calibration. Incorrect calibration of this equipment may lead to false and inaccurate navigational readings placing the yacht into danger.

Warning: Operational Hazard

The H3000 system is an Electronic Navigation aid and is designed to assist in the navigation of your yacht. It is not designed to totally replace conventional navigation procedures and precautions and all necessary precautions should be taken to ensure that the yacht is not placed into danger.

The Pilot is an aid to steering the vessel. It is the users responsibility to ensure the safe control and movement of the vessel at all times.

Caution: Electrical Supply

This equipment is designed for use with a power supply source of 12V dc. The application of any other power supply may result in permanent damage to the equipment.

Caution: Cleaning

The use of alcohol or solvent-based cleaners will damage this equipment and any warranty in force will be invalidated.

Caution: Display Installation

Displays installed into locations manufactured from conductive materials (e.g. Steel, Carbon Fibre etc.) should be insulated from the structure to prevent damage to the casings as a result of the effects of electrolysis.

Caution: Processor Installation

All B&G Processors should be installed below decks in a dry location protected from water and moisture.

Power Off Disclaimer

When in standby mode the H3000 system continues to consume power. To conserve the vessel's battery life switch off power at the main breaker.

ABOUT B&G

B&G has welcomed the constant challenge to develop new electronic solutions for every sailor's need. Harnessing technical developments and providing proven solutions has continued to be the focus that keeps B&G on the leading edge of advanced marine electronics.

Proven in the world's most testing environments, B&G offers the most accurate and reliable systems used by blue water cruisers, single-handed racers and record breakers alike firmly establishing ourselves as one of the leading innovators of the most highly advanced marine electronics. B&G is renowned for tried and trusted solutions and is ever evolving to offer the best technology to the customer.

B&G's Promise.

“Uncompromising performance, precision and reliability from both our products and our people”.

ABOUT THIS HANDBOOK

Instructions in this handbook describe the controls and calibration of your H3000 Pilot system. You can also use the controls on the RemoteVision.

All functions described in this handbook refer to the standard Hydra processor settings unless indicated with a Hercules logo as shown below.

HERCULES

Indicates that the information listed relates to Hercules processor functionality which includes Hydra functions.

PERFORM

Indicates that the information listed relates to Performance processor functionality which includes Hercules and Hydra functions.

Please contact your local dealer if you wish to upgrade your processor. A list of B&G approved dealers can be found at www.bandg.com

SYSTEM INTRODUCTION

The H3000 Pilot fully integrates with the H3000 instrument system, both in terms of style and performance. The instrument system transmits sensor information via the B&G Fastnet network to the ACP Pilot computer unit.

The Pilot computer processes the sensor data and then sends signals to the rudder drive system (linear ram, rotary drive or hydraulic pump) to steer the vessel on the desired course. The complex learning algorithms used in the Pilot computer ensure that the steering performance is optimised for the sea and weather conditions, and quickly responds to any changes that may occur.

Control of the Pilot is via the keys on any one of the dedicated Graphical Pilot Displays (GPD). Each display acts as a master allowing control of the Pilot from any station.

H3000 Pilots are available with a wide range of powerful and reliable 12V or 24V dc rudder drive units suitable for boats of over 7m (23ft). The ACP (Advanced Control Program) Pilot computers are supplied in two specifications ACP1 or ACP2 (Advanced Control Programming) depending on the size of vessel, power requirements and options in use.

The H3000 Pilot can be used for both sailing and power boats that have a H3000 System installed.

H3000 SYSTEM EXAMPLE

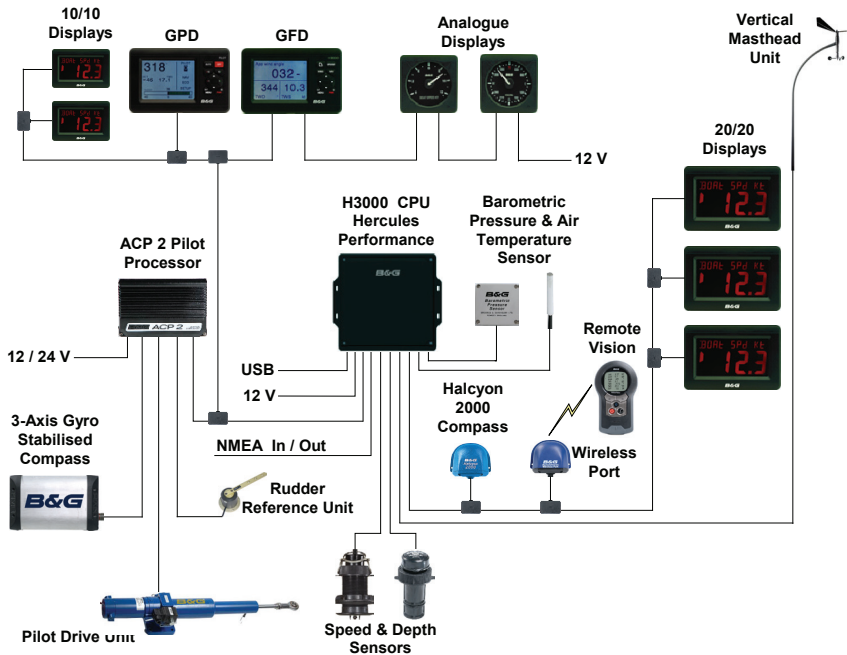

H3000 System example with Pilot Processor H3000 ACP

Above is an example of a typical H3000 system. At the centre of the system is the Central Processor Unit (CPU).

All sensor information is fed back to the CPU and can be easily controlled and configured via the Graphical Function Display (GFD).

The ACP Pilot processor integrates with the CPU to optimise the performance of the B&G system providing data for the autopilot to steer the boat.

H3000 PILOT ACP

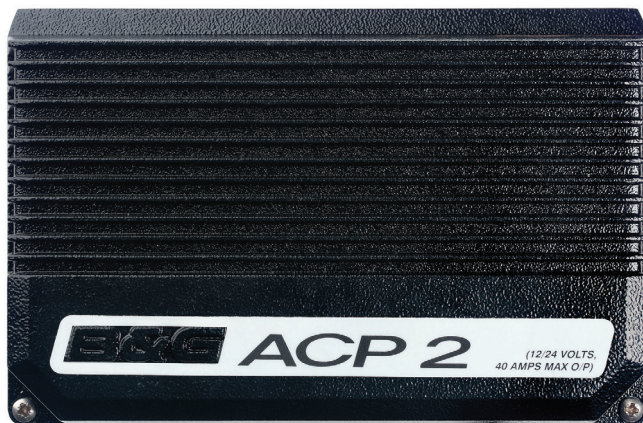

The B&G H3000 Pilot Processor has been proven in the world's most testing environments.

Used by bluewater cruisers, single handed sailors and record breakers alike the ACP takes on the role of an extra crew member who never tires and can be called upon 24 hours a day to take control of your boat and sail it in your desired direction.

- The ACP can be set to:
- Steer to compass
- Steer to Apparent or True wind angle
- Steer to waypoint
- Power steer mode (Enables you to manually steer the pilot via the Graphical Pilot Display (GPD))

The Pilot offers smart tack & gybe, enhanced response and recovery features as well as auto response for optimum course keeping. (requires Halcyon Gyro-Stabilised Compass (HGSC))

GRAPHICAL PILOT DISPLAY (GPD)



The GPD utilises a high-resolution graphical display that allows the use of a very intuitive user interface, and flexible data representation.

Monochrome and colour versions are available. The monochrome version is intended for on-deck use and viewing from distance, the colour version is designed to allow additional clarity in short-range applications such as navigation stations, cabins, pedestal mounts etc

The GPD has a simple, easy to learn, user interface and keypad layout that simplifies the operation and configuration of the system.

There are dedicated keys for direct Pilot control (Auto, Off, 10° port, and 10° starboard) as well as the menu navigation keys used on the GFD.

It is possible to display a number of user configurable instrument pages, and access the main H3000 setup and control menus as per the GFD.

Index matched bonded display technology is used to give the dual benefits of increased display clarity in all lighting conditions and complete elimination of the possibility of condensation obscuring the display.

HAND-HELD CONTROLLER



The Hand-held Controller provides a wired remote control of the H3000 Pilot. The six keys used for dedicated functions are as follows:

- 10 degree course change (Port/Starboard)
- 1 degree course change (Port/Starboard).
- Auto/Resume - Pilot engage and return to course.
- Off - Pilot disengage.

JOYSTICK

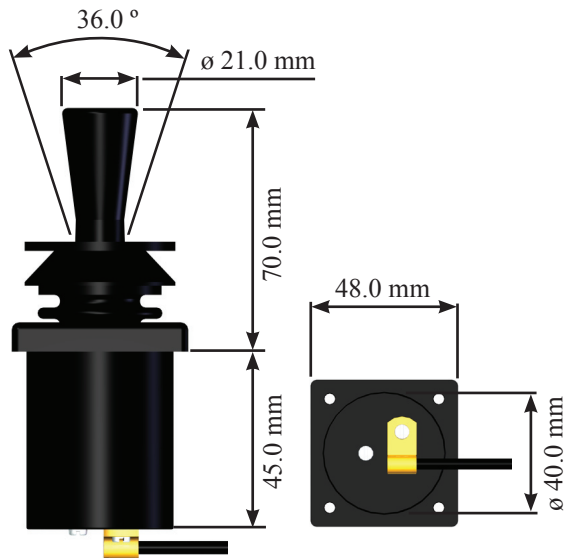

The Joystick allows direct control of the rudder via the Pilot control electronics. The unit is deck-mountable, allowing it to be used internal or external steering positions. A 10m (30ft) 6-core screened cable connects the unit directly into the ACP. Joystick steering is engaged and disengaged with the separate red control button. The lever controls the port and starboard movement of the rudder.

There are two modes of joystick operation available to the Helmsman, these are as follows:

Normal Steering ~ The rudder moves in the direction of the Joystick. When the Joystick is returned to the central position the rudder movement stops. The greater the movement of the Joystick the faster the response of the rudder.

Proportional Steering ~ The position of the rudder follows the position of the Joystick. When the Joystick returns to the central position the rudder returns to its initial position.

MAN OVERBOARD BUTTON

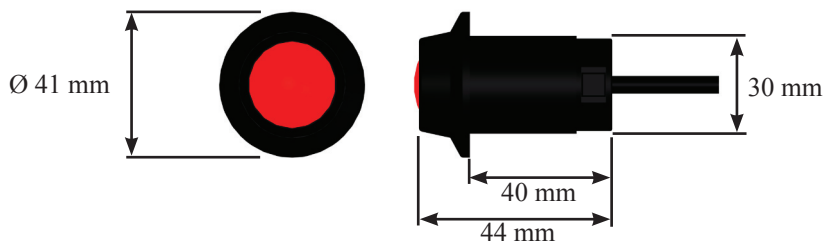

The Man Overboard (MOB) button is an optional extra that activates the Pilot's Man Overboard procedure to assist in the recovery of the person, or persons, that may have been lost overboard.

The MOB facility will operate when the system has a valid source of boat speed in use (not Manual Speed or SOG). It will function whether the Pilot is engaged or not.

Two modes of operation are available, Manual Recovery and Automatic Recovery.

Manual Recovery ~ Displays Range and Bearing to the MOB position on the GPD, GFD and FFD displays to enable the crew to steer the boat back to the MOB position. The range and bearing is calculated by dead reckoning so tidal influences are effectively corrected for.

If you have a GPS MOB facility you should also activate this to store a geographic MOB position. Manual recovery is available for both sailing and power boats.

Automatic Recovery ~ Allows power boat users to follow the range & bearing function with a request to the Pilot to carry out a Williamson turn which will bring the boat back in the vicinity of the MOB position.

Manual Recovery procedure:**WARNING**

This procedure is in addition to standard MOB practices, ensure that you and your crew are familiar with normal MOB procedures.

- 1) Press the MOB button as soon as the person is lost overboard. The alarm will sound (if fitted) and the displays will show the Man Overboard message. The GFD, GPD and FFD displays will now show the bearing and distance to the person overboard. On FFDs the bearing will be flashed three times and then the distance (in Nautical Miles) once, this pattern will repeat until cancelled.
- 2) Maintain a lookout and keep visual contact with the person in the water. Steer the boat back to the person overboard following the bearing and distance displays. The boat can be steered using the course change buttons when the Pilot is engaged, or press the red Off Key to disengage the Pilot and steer the boat manually. Recover the person overboard.
- 3) To end the MOB sequence press and hold the MOB for 5 seconds. The displays of bearing and distance are cancelled and the Pilot will return to the normal (previous) setting. Alternatively select Silence on a GFD or GPD alarm window, or click Enter twice on a FFD.

Automatic Recovery procedure:**WARNING**

This procedure is in addition to standard MOB practices, ensure that you and your crew are familiar with normal MOB procedures. If you are unfamiliar or unsure of the Automatic Recovery mode do NOT use it, use manual recovery and standard MOB practices instead.

- 1) Press the MOB button as soon as the person is lost overboard. The alarm will sound (if fitted) and the displays will show the Man Overboard message. The GFD, GPD and FFD displays will now show the bearing and distance to the person overboard.

On FFDs the bearing will be flashed three times and then the distance (in Nautical Miles) once, this pattern will repeat until cancelled.

- 2) Maintain a lookout and keep visual contact with the person in the water. Reduce the boat speed to less than 8 knots. Ensure that the area is clear of other boats and obstacles.
- 3) Press the MOB three times in quick succession to initiate an Automatic Recovery. The Pilot will control the steering and execute a Williamson Turn. AT ANY STAGE you may press the red Off Key to disengage the Pilot and steer the boat manually. Recover the person overboard.
- 4) To end the MOB sequence press and hold the MOB for 5 seconds. The displays of bearing and distance are cancelled and the Pilot will return to the normal (previous) setting. Alternatively select Silence on a GFD or GPD alarm window, or click Enter twice on a FFD.

OPERATING INFORMATION

SWITCHING ON

The H3000 Pilot has two power supplies (instrument and heavy duty rudder drive supply) these are normally connected via circuit breaker. The Pilot computer and Pilot displays are powered via the Fastnet network cable and share the same source of power supply as the H3000 instrument system.

The hydraulic ram, rotary drive or hydraulic pump supplies are routed via the Pilot computer. The heavy-duty supply is dedicated to the rudder drive unit and is connected via a separate heavy-duty fuse or circuit breaker.

To switch the Pilot ON, proceed as follows:

- Switch ON the instrument supplies.
- Switch ON the heavy-duty power supply for the rudder drive unit.

The Pilot will only operate if both the heavy duty and instrument supplies are switched ON.

Notes:

- If the Pilot Display indicates Fault 115 when engaged for the first time, check that the heavy-duty drive supply is switched ON. If it is off switch ON the heavy-duty supply and clear the fault message.
- If the Pilot Display shows Fault 104 when engaged, this indicates that there is no boat speed input from the sensor. This is normal if the Pilot is switched on at the dockside.

GETTING STARTED

GRAPHIC DISPLAY (GPD) KEYS EXPLAINED

Power / Lights

To power on/off the GFD press and hold the Power key until the unit powers up/powers down. At start up the last page used on the previous operation will be displayed.

A Short press of the Power key will provide full background illumination on all system displays. Further short presses of the key decrease the illumination in three stages from full brightness to OFF. The next press of the key enables full illumination. Display lighting can be localised so that the level is adjustable for individual displays.

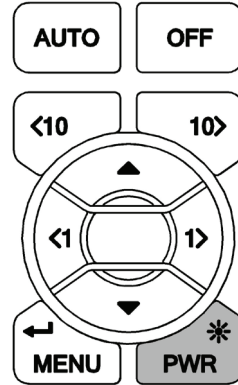

Menu / Enter

The Menu/Enter key either activates the main menu or actions a menu item.

When the GPD is in compass mode NORMAL pressing the menu key (MENU) will bring up the main menu as shown on page 21

However if a menu item is highlighted the key acts as an enter key to select the menu choice.

If editing a parameter this key also confirms the new value.

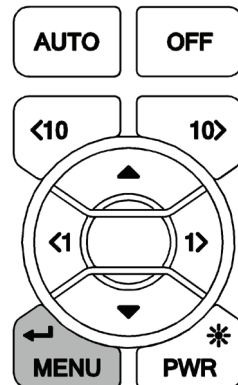

Pilot function keys

These are dedicated function keys that will control the Pilot regardless of which menu you are navigating.

Pressing one of these keys whilst in any menu will bring up the Pilot screen and perform the relevant function at the same time.

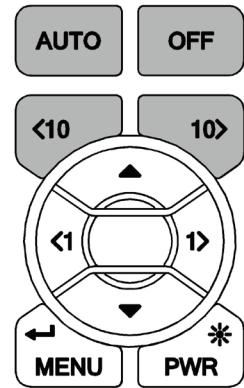

Auto: When the Pilot is in standby a single press engages the Pilot. The Pilot screen will be displayed.



Off: (RED Button) When the Pilot is engaged a single press disengages the Pilot. The Pilot screen will be displayed.



10° Port: This is a 10° degree dodge function that changes the Pilot course by 10° Port. The Pilot screen will be displayed.



10° Starboard: This is a 10° dodge function that changes the Pilot course by 10° Starboard. The Pilot screen will be displayed.

WARNING ~ Pressing the Auto key when the Pilot is disengaged will engage the Pilot. Pressing the Off key when the Pilot is engaged will disengage the Pilot. Be aware of your Pilot status before your use these keys!

1° Keys

These function keys change the Pilot course by 1° Port or 1°Starboard as applicable. When in compass mode you can use these keys to pre-set the course.

When navigating menus they perform as left and right action keys. Un this mode they do not affect the Pilot course.

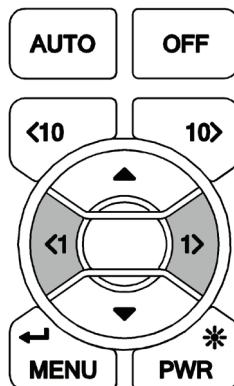

Up & Down

Navigate up and down within the Pilot screen and standard menu modes.

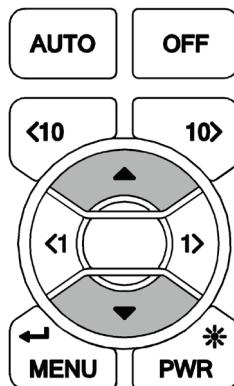

GPD MENU STRUCTURE

The central concept to the operation of the GPD is the menu system; once this is grasped operation very quickly becomes familiar. The idea of structured layers of menus is seen everywhere in modern software, and regular mobile phone or computer users should have a head start.

The principle is that at any one level there is a set of choices that you can scroll through until you find the one you want. Having found the correct menu entry, it is then selected by pressing ↵ (or ► key) the GPD then displays the next menu down.

Here you again scroll through the available options until you find and select your choice. In many cases this is as far as you will need to go, e.g. to choose a function for display. To complete some actions such as entering a calibration value, switching on an alarm, and so on, you will need to navigate the GPD menus. Throughout this handbook there are some standard formats used to assist you.

Each menu choice selected will be in CAPITALS. The page description / contents will be in lower case.



Indicates the menu key should be pressed to enter Main Menu



Indicates scroll right, to enter a sub menu



Indicates scroll left, to return to the previous menu



Indicates scroll down / Reduce value



Indicates scroll up / Increase value



Indicates press Enter to confirm an action



Indicates 1° right



Indicates 1° left





Indicates dodge 10° right



Indicates dodge 10° left

At any time during the navigation of the GPD, press the  key to return to the Pilot screen, and engage the Pilot.

At any time during the navigation of the GPD, press the  key to return to the Pilot screen, and disengage the Pilot.

At any time during the navigation of the GPD, press the   keys to return to the Pilot screen. If the Pilot is engaged it will dodge 10° in the direction that corresponds to the key press.

Example 1 ~ Engaging the Pilot

At anytime whilst the Pilot is disengaged press  to engage the Pilot. The Pilot will steer the boat to the currently selected course for the mode selected. e.g. in compass mode the current heading is selected as the desired course. In WIND T mode the Pilot will steer to the current TWA (True Wind Angle).

Example 2 ~ Disengaging the Pilot

Press  to disengage the Pilot. The Pilot will be switched off and you will be required to take manual control of the wheel.

Example 3 ~ To set a course from the Pilot screen

You must be on the Pilot screen and the Pilot must be engaged for you to be able to utilise this function.

▼ Highlight SET COURSE ↵ ▲▼ Set the required course ↵

Example 4 ~ To set an alarm function.

SETUP ► ALARMS ► Select Alarm ► Input Value ► Toggle ON/OFF ↵

Example 5 ~ Watch Alarm

The Pilot will sound an alarm (if an audible alarm is installed to the Instrument system) and cause all the system displays to display a warning at a pre-set time interval to keep the helmsman and crew alert. There are two selections:

OFF: The alarm is disabled (default).

ON: 1 to 360 - A number is set in minutes. The alarm is enabled when the value is entered.

To set-up WATCH alarm:

SETUP ► ALARMS ► WATCH ► Using ▼▲ Set the required time ► Using ▼▲ turn on watch.

GPD MAIN MENU

Pressing the  key will display the main menu.
 Below is a list of the menu options, their functions, or setup information.

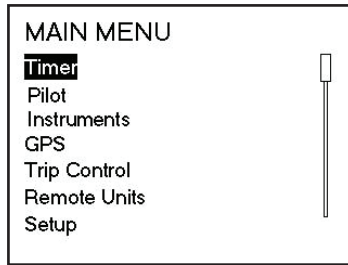

TIMER

The timer is designed as a start / elapsed timer; it will count up from zero and will count down to zero if a time value is set.

TIMER ► ▼

- SYNC** ↵ Jumps to the nearest whole minute. i.e. 4:45 or 5:07 both become 5:00
- START** ↵ Starts Timer
- SET** ↵ ▼ ▲ (Set countdown timer value) ↵ To timer menu

PILOT

Selecting Pilot will take you to the Pilot screen.

PILOT ► Pilot Data Page

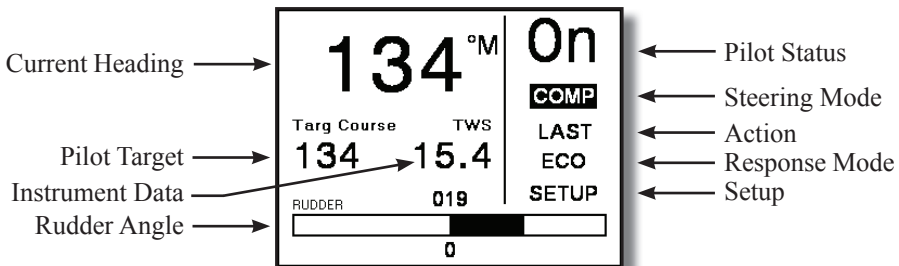

Current Heading

- Current system Heading

Pilot Target

- Desired Course, Wind Angle, Bearing to Waypoint or Cross Track Error.

Note: This will display different types of data determined by which steering mode is selected.

Instrument Data

- Displays one item of data from the H3000 Instrument system. TWS is the default but this can be changed to show any of the H3000 systems instruments data.

Rudder Angle

- Graphic in 1-degree resolution, to Port or Starboard.
- Numeric value shown above graphic

Pilot Status "ON" or "OFF"

Can be controlled by the ON/OFF keys on Pilot display, or RemoteVision.

Steering Mode Indication

- COMP - Steer to Compass
- WINDA - Steer to Apparent Wind
- WINDT - Steer to True Wind
- NAV - Steer to Waypoint
- POLAR - Steer to Target TWA.
- POWER - Manual steering via the GPD Port & Starboard keys

Action

- Last – Last course –Option in COMP mode
- Next – Next waypoint – Option in NAV mode
- Tack – Tack on command – Option in WINDA & T modes
- Gybe – Gybe on command – Option in WINDA & T modes
- Mid – Return to mid position – Option in POWER mode

Response Mode

- ECON – Economy: The rudder movement is limited; this reduces the overall consumption of the autopilot system.
- NORM – Normal course keeping and rudder response.
- DWIND – Downwind: More active steering control especially for downwind steering in demanding conditions.

- PERF1
- PERF2
- PERF3
- PERF4

Note: ECON consumes the least amount of power when steering the Pilot but offers the slowest response to the Pilot processors information. PERF4 consumes the most power but has the highest response time.

Setup shortcut

- Advanced Settings Menu.

This menu can also be found via: MENU ► SETUP ► COMMISSION ► PILOT ► ADVANCED SETTINGS

See Page 64 for Advanced Settings

INSTRUMENTS

There are six pre-set pages of instrument data.

INSTRUMENTS ►

Use the ► key to step through each of the instrument pages.

Page 1: Boat Speed - Velocity Made Good (VMG)

Boat Speed	kt
7.47	
u5.47	
VMG	kt

► Page 2: Boat Speed - True Wind Angle

Boat Speed	kt
7.48	
=43	
True Wind Angle	°

► Page 3: Timer, Boat Speed - True Wind Direction

Timer	
08:17	
7.48	081
Boat Spd kt	True W/D°M

► Page 4: Apparent Wind Angle - Apparent Wind Speed - True Wind Angle - True Wind Speed

App W/A °	App W/S kt
- 31	25.5
=43	19.5
True W/A °	True W/S kt

► Page 5: Boat Position – Speed Over Ground – Boat Speed – Distance to Waypoint – Course Over Ground – Heading – Bearing to Waypoint - Local Time

Boat Position		
50° 45.10 S		00:02:24
001° 27.40 E		
SOG	Boat Spd	DTW GC
7.63	7.47	1.1
COG	Heading	Brg Wpt
132	134	138

► Page 6: Steering Compass Graphic

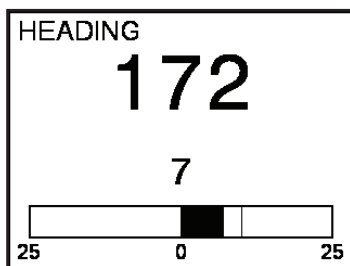

Displaying temporary information on any instrument page

It is possible to quickly access additional information from the instrument pages, you can display this data by following the example below.

To change the display data whilst navigating the instrument pages,

Select the page you wish to temporarily change ▼

Highlight the data you wish to change ↵

Select the new data to be displayed ↵

Note: Any changes in configuration made to the current display page by this method are not stored, the page will return to its previous configuration when any other display page is selected. To permanently change contents see page 37

GPS

There are two pages that show GPS data.

Page 1 shows nine pieces of data:

Boat Position – Speed Over ground – Boat Speed – Distance to Waypoint – Course Over Ground – Heading – Bearing to Waypoint – Local Time

Page 2 has a rolling road with three pieces of data: Distance to Waypoint – Cross Track Error – Bearing to Waypoint. Both shown below.

GPS ► GPS Data Page 1 ► GPS Data Page 2

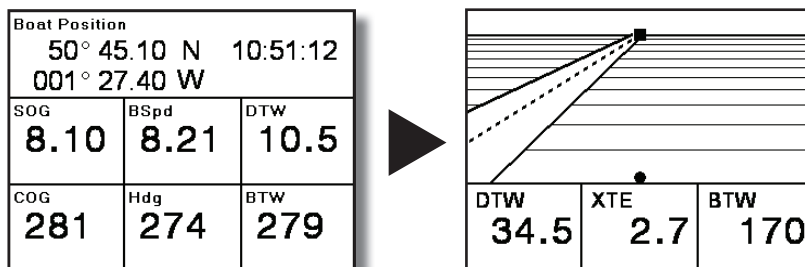

Note: This Information relies on a suitable GPS interfaced to the H3000 via NMEA 0183, or the USB port.

TRIP CONTROL

This page shows all trip functions in one menu including the stored log that allows easy access to reset and start operations. The stored log is also displayed but cannot be reset.

When any trip function is started, all other trip functions that have been reset start simultaneously, except when the timer countdown is started. Under this condition, the other functions start, again if previously reset, when the countdown reaches zero.

This is designed for the beginning of races, so that you have DR, log and timer running automatically, from the race start time.

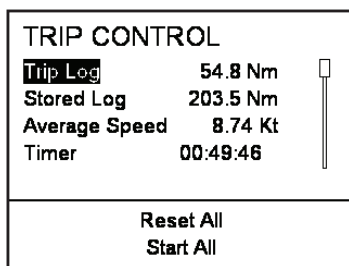

Example 1 ~ Reset Trip Log

TRIP CONTROL ▶ Trip Log ▶ ▼ Reset ⌵

Example 2 ~ Start all trip functions.

TRIP CONTROL ▼ Start All ⌵

REMOTE UNITS

This option provides remote control of any 20/20 or 40/40 type display. Below is an example of how to change the data shown on display 1.

REMOTE UNITS ► Display 1 ► Boat Speed ▼▲ Select one of the 14 preset data pages ◀ Scroll left to save the new display data

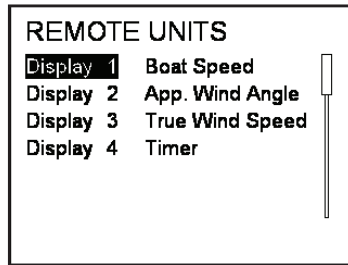

Note: When a display is selected, as shown above, the remote display will flash so you can identify the physical display unit you are controlling.

Below is an example of how to change any of the pre-set pages to display alternative data.

REMOTE UNITS ► Display 1 ► Boat Speed ↵

**This will display the data menu ► Highlight the required piece of data
↵ Will bring you back to the remote units page.**

Note: The selected function data will then be stored in that particular remote display's preset page.

SETUP

The Setup menu provides access to system alarms, calibration, damping, this display, and commissioning.

Alarms

SETUP ► ALARMS

You can preset alarm parameters to trigger a warning when the set limits are reached. This will flash a message on the display to warn you. An audible alarm can also be installed. Any user alarm can be switched on or off.

There are 3 types of alarm. Hi, Low and Sector. The sector alarm is activated if you move outside a specified sector angle.

When an alarm is on and that alarm is triggered it will send a warning message to all GPDs and GFDs. FFDs will flash with the function that has triggered the alarm. If you select ignore then the alarm will not be displayed on that individual unit, but will continue to be shown on all other displays until silenced.

If you select 'silent' the warning screen will disappear on all displays. The alarm will automatically become active again once you move back within the alarm limits.

Each time the alarm zone is reached it will trigger the alarm. You must set the alarm to off to deactivate it completely.

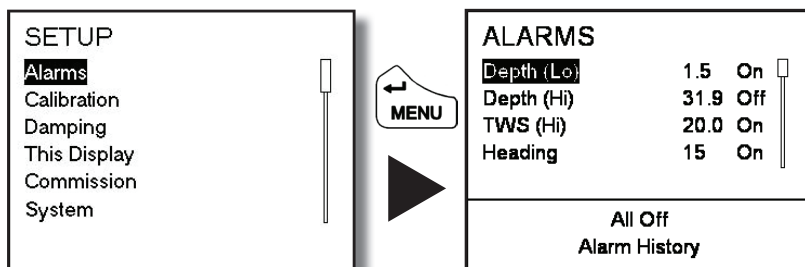

Note: All alarms can be turned off by highlighting ALL OFF in the alarms menu and pressing ↵

Note: Only the common alarms are listed. For other available alarms go to **ALARMS ► OTHER ALARMS**

Example 1 ~ Setting Depth Low Alarm

SETUP ► ALARMS ► Depth (Low) ► Set ▼▲ Lo limit ► Switch ▼▲ On/Off

Example 2 ~ Accessing Alarm History

SETUP ► ALARMS ► ALARM HISTORY ↵

Alarm History displays all alarms that have been triggered. This information is cleared when the power is switched off.

Example 3 ~ No (or Low) Boat Speed Alarm

In the screen shot below the ‘No (or Low) Boat Speed’ Alarm is shown. To accept and clear remove the alarm window globally from all GFDs select **SILENCE** and press ↵, if you wish to remove this warning from the display you are using select **IGNORE** and press ↵

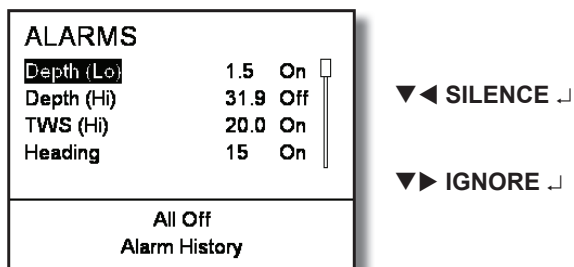

Calibration

SETUP ► CALIBRATION

It cannot be over stressed how important it is to calibrate the system properly, in both the initial stages of the installation and operation, and throughout the life of the system.

Calibration is an ongoing process and is something you must be aware of each time you go sailing. This is particularly relevant of the true wind calibration, where constant refining will pay huge dividends in accuracy.

To this end the process has been simplified as far as possible, so that all you require for accurate instrument data is some background knowledge together with a few simple techniques.

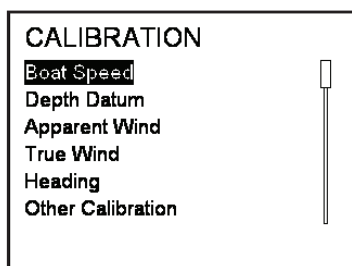

Note: *Information regarding calibrating your H3000 system can be found in the H3000 Instrument Handbook.*

Compass Calibration

B&G's Autoswing compasses contain software that allows them to record the magnetic fields in the yacht that are causing deviation errors. It calculates the corrections when the COMP CAL function is started and provided the following conditions are met: -

The 360° turn - Halcyon 2000 and Halcyon Gyro Stabilised Compass is completed in the same direction.

The rate of change of heading does not exceed 3°/s; i.e. the turn should take about 3 minutes to complete.

The rate of change of heading must not fall below 0.2 of a degree per second during the 360° turn, i.e. the turn must not take longer than 12 minutes.

The rate of change in heading is reasonably constant.

The compass is installed in a location a safe distance from magnetic interference such as iron keels, engines, loudspeakers etc.

Consideration should also be given to electrical cables which may carry high currents (e.g. large motors).

The compass is installed in a location as close to the centreline of the boat as possible. Avoid areas such as the fore peak and the sides of the hull where the effects of pitch and roll are at their greatest.

On steel hulled vessels, the compass will need to be installed above decks away from the effects of the hull.

Halcyon 2000 Compass Calibration

Check for any magnetic devices placed near the compass, especially ones that are out of their normal places.

On a calm day select a stretch of open water with little traffic (so you will not have to take avoiding action which would affect the calibration). The flatter the water and the less the wind the easier it will be to meet the conditions for calibration.

Check for and avoid sailing close to any large steel structures nearby, that may cause additional, erratic deviations.

Now select:-

SETUP ► COMMISSION ► START COMPASS SWING ►

The display will now show the degrees of turn completed so far. When the full 360 deg turn has completed within the limits described earlier, the display should say “PASS” to indicate a successful swing.

A “FAIL” indication suggest that the turn was not completed within the guidelines or quite possibly that there is too great a magnetic influence close to the sensor. This will require investigation before the swing process is retried.

Now the swing is complete its important to eliminate any constant error in heading due to the physical alignment of the sensor relative to the fore / aft line of the boat.

This is normally checked for by using shore-based transits, once the error is known it can be eliminated by entering the value into the system under:

SETUP ► CALIBRATION ► HEADING ► SET OFFSET VALUE ► (Enter new value) ↵

For example, the compass was reading 320° and it should read 316°, then the value to enter would be -4° from the current set value

Note: The first time the system is switched on, or after a system reset, the Heading will alternate with CAL. This is to indicate to the user that the compass must be calibrated. This will disappear after the compass has been swung correctly.

Halcyon Gyro Compass Calibration and Setup

This section describes the setup and calibration of the Halcyon Gyro compass connected to the H3000 system via the Halcyon Gyro Processor unit.

The conditions and preparations for performing an Auto swing are the same as described in the previous section for the Halcyon 2000 Compass.

Once ready to start the swing select:-

SETUP ► CALIBRATION ► OTHER CALIBRATION ► MISC ► HALCYON ► START ► (Set value to 1 starts swing) ↵

The display will now show the degrees of turn completed so far. When the full 360 deg turn has completed within the limits described earlier, the display should say, “PASS” to indicate a successful swing.

A “FAIL” indication suggest that the turn was not completed within the guidelines or quite possibly that there is too great a magnetic influence close to the sensor. This will require investigation before the swing process is retried.

Now the swing is complete its important to eliminate any constant error in heading due to the physical alignment of the sensor relative to the fore / aft line of the boat.

This is normally checked for by using shore-based transits, once the error is known it can be eliminated by entering the value into the system under:

SETUP ► CALIBRATION ► HEADING ► SET OFFSET VALUE ► (Enter new value) ↵

For example, the compass was reading 320 degrees and it should read 316, then the value to enter would be -4 from the current set value

Heading Source Selection

The H3000 System can accept heading data from a variety of different sources. These different sources are known as Nodes and allow the system to identify which heading devices are connected to the system.

DAMPING

SETUP ► DAMPING

Another important facility that you need to be constantly aware of is the damping available on certain functions. This allows you to filter signal noise on the function when in unstable or rough conditions.

The damping works by applying a filter over a time period; the more you increase this time period, the smoother the data readings will be, but the longer it will take to see the effect of any change. Similarly the lower the time period the greater the jumps you will see in the numbers, but the response to any change will be faster. It is recommended to use the smallest value which still gives stable data.

Dynamic Damping

Dynamic Damping adjusts your system to deliver the most accurate and real-time information, i.e. when on a beat, it is essential that the wind angle information is accurate but steady with most 'noise filtered out, however, when tacking, data

needs to be more real-time. With Dynamic Damping, the damping value applied will reduce to almost zero during conditions when the data is changing rapidly and then settles again after the tack.

The Damping value is set (in seconds) to a steady state value, the Dynamic Damping is set to a value between 0 (off) and 10 (maximum), the higher the value, the more sensitive the function is to rates of change, and the faster the damping value is lowered.

This allows the effects of the change to be more readily seen on the instruments. As the rate of change of the function reduces, so the damping value is allowed to rise to the preset Damping Value to ensure signal noise is filtered out of the data.

Damping should not be confused with the update rate which is the number of times per second that the function value is sent to the display. The update rate is fixed for all the functions.

DAMPING	
Boat Spd	4
App Wind Spd	05
App Wind Ang	3
True Wind Spd	01
True Wind Ang	3
Heading	00



Example 1 ~ Set Boat Speed Damping

SETUP ► DAMPING ► BOAT SPD ► Set Value ↵

THIS DISPLAY

SETUP ► THIS DISPLAY

THIS DISPLAY menu is where you can modify the general settings of the GPD. Any changes to the default settings will be saved. To return to default settings go to:

SETUP ► SYSTEM ► RESET OPTIONS ► THIS DISPLAY. This will only affect the individual display unit.

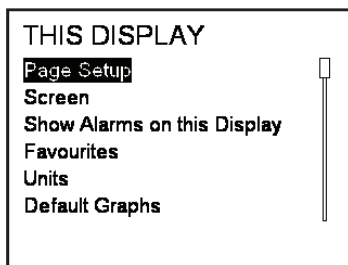

Page Setup

You can reconfigure the Instrument pages are accessed from the Main Menu. You can change the default pages, and change how each page is configured.

Screen layouts can be selected for each page and configured to display whatever data is required. Once this has been changed it is saved for future use.

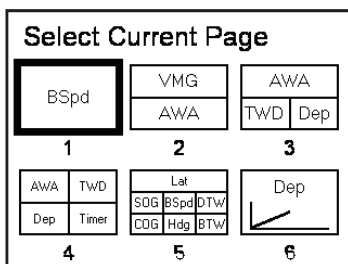

Example 1 ~ To change data displayed on page 1

Highlight the page that you want to reconfigure ↵

Select which page format you desire ↵

Highlight the display pane you wish to reconfigure ↵

Select the new data you wish to be displayed ↵

***Note:** reconfiguring the page key in this manner will permanently change the displayed data. To return to the default pages see reset defaults on page 36*

Displaying temporary information on any data page

To enable you to quickly access additional information whilst navigating the data pages you can display this data by following the example below.

***Note:** Any changes in configuration made to the current display page will return to its previous configuration when any other display page is selected.*

Screen

The screen option allows modification of Lighting and Contrast settings.

SCREEN ▶▼ Highlight lights control ▶ Select local or system ▼

Highlight colour ▶ Select Red or White ▼

Highlight contrast bar ◀▶ to modify contrast

Show Alarms on this Display

Enable or disable alarms appearing on an individual display. This function is useful where many displays are installed next to each other and it is unnecessary for all to show alarms.

Favourites

Favourites enables you to configure six pieces of the most commonly required instrument data. Normally these are six additional pieces of data that are not already allocated to the page keys.

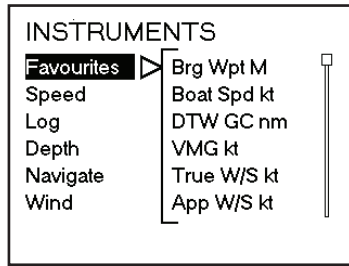

Example 1 ~ Modifying the favourites menu.

FAVOURITES ► (Select data header you wish to change) ⌵

Highlight top-level data menu heading e.g. SPEED ►

Select type of data e.g. BOAT SPEED Kt ⌵

Units

Allows you to configure the units and type of measurement used for Heading, Wind Speed, Depth, Boat Speed, and Nav Mode.

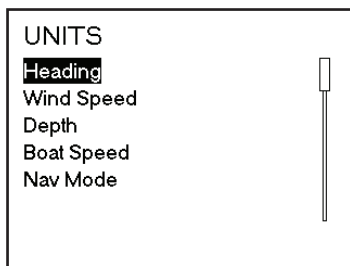

Example 1 ~ Changing the Heading reference from Magnetic to True.

UNITS ► HEADING ► TRUE °T ◀

GFD Units of Measurement			
Type	Options	Abbrev	Default
Heading	Magnetic	°M	Magnetic / °M
	True	°T	
Wind Speed	Knots	Kts	Knots / Kts
	Metres/s	m/s	
Depth	Metres	m	Metres / m
	Feet	Ft	
	Fathoms	Fm	
Boat Speed	Knots	Kts	Knots / Kts
	Km Per Hr	KPH	
	Miles Per Hr	MPH	
Nav Mode	Great Circle	GC	Great Circle / GC
	Rhumb Line	RL	

Unit Information

Displays the current software version operating in your H3000 system

SETUP ► THIS DISPLAY ► UNIT INFORMATION ►

Key Lock

Pressing and holding the Menu and Lights key together will lock the keys to the GPD. There are two key lock settings that you can choose from.

All Keys	Locks all keys except the OFF key
Pilot Keys	Locks Auto, OFF, ◀10° & 10°▶

All Keys is the default setting. Whichever key lock setting you select will be remembered

COMMISSION

From the commission menu you can setup the H3000 system. From here you can decide to use SOG as boat speed, set which compass is being used, commission the Pilot, start a compass swing and setup a second depth input.

SETUP ► COMMISSION

Use SOG as Speed Input

This sets the speed source used by the instrument system.

Choose between Boat Speed and SOG (Speed Over Ground) as your speed input. The default setting takes speed input from the paddle wheel sensor.

If you choose to use SOG instead of boat speed this will take data from your GPS input. This can be used in the event of damage/fouling of the paddle wheel sensor and/or on very high-speed vessels where the sensor has limited contact with the water.

Note: *If SOG is selected the Pilot will also be using SOG even if set to use boat speed. If you wish to use SOG only on the Pilot refer to page 65.*

Example 1 ~ Use SOG as speed input

COMMISSION ► USE SOG AS BOATSPEED ► ON/OFF ▼▲ ↵

Heading

This setting controls the source of heading data used by the instrument and Pilot system.

Select the heading source:

Device	Node
CPU (NMEA Input)	5
Halcyon Processor (“Halcyon Gyro” Input)	15
Halcyon Processor (NMEA Input)	15
Halcyon 2000 Compass	16
ACP Pilot (Direct “Halcyon Gyro” Input)	18
NMEA Input to NMEA FFD	96,97...

Example 1 ~ Set the heading source to use a Halcyon Gyro-Stabilised Compass connected directly to the PILOT ACP

COMMISSION ► HEADING ► Select Source (18) ▼▲ ↵

Pilot

The Pilot can be fully commissioned via the GPD. For full detailed instructions on how to do this please refer to page 56

COMMISSION ► PILOT

Start Compass Swing

Example 1 ~ Starting a compass swing.

COMMISSION ► START COMPASS SWING ↵

Note: *The compass swing will automatically finish once a 360° turn has been*

completed. If the commission has been successful then the display will show PASS. If unsuccessful the display will show FAIL and the process will need to be repeated.

System

From this menu you can look up software versions and reset any B&G equipment on the network.

Example 1 ~ Reset Options – How to reset this display

**SETUP ► SYSTEM ► RESET OPTIONS ► THIS DISPLAY ► Reset this display
▼▲ YES/NO ↵**

Example 2 ~ System Versions - How to check the software versions currently installed on the system.

SETUP ► SYSTEM ► SYSTEM VERSIONS ► THIS DISPLAY ► Shows current software version for that display.

PILOT OPERATION

ENGAGING THE PILOT

From the Pilot Display: Steer the boat on the desired course, press the AUTO key to engage the Pilot.

From the Hand-held Controller: Steer the boat on the desired course, press the Auto/Resume Key to engage the Pilot.

DIS-ENGAGING THE PILOT

Note: *When the Pilot is engaged, the instrument system GFD and FFD Power-Off keys are disabled, preventing accidental switching OFF of the Pilot whilst in use.*

At any Pilot Display press the Red Off Key. The Pilot immediately disengages and returns the boat to manual steering.

From the Handheld Controller press the Red Off Key. The Pilot immediately disengages and returns the boat to manual steering.

CHANGING THE PILOT COURSE

Note: *The Pilot can be immediately disengaged and the steering returned to manual control by pressing the Red Off Key on any Pilot Display or Hand-held Controller.*

Fine Adjustments - Multiple key operations are added together to give the required course change, e.g. for a 5° course change press the 1° button 5 times.

Coarse Adjustments - Multiple key operations are added together to give the required course change, e.g. for an 11° course change press the 10° + 1° button.

PILOT MODE SELECTION

The Pilot software automatically determines which modes of operation are available depending on the boat type selection and available data.

When first switched ON the Pilot will be in Standby and Steer to Compass (COMP) mode.

There are up to 6 modes to select from:

Mode	Description
COMP	Steer to Compass
WIND A	Steer to Apparent Wind Angle
WIND T	Steer to True Wind Angle
NAV	Steer to Waypoint
POLAR	Steer to Target True Wind Angle
POWER	Manual Steering via the GPD Port & Starboard Buttons

The mode is changed by highlighting the mode indicator and press \downarrow

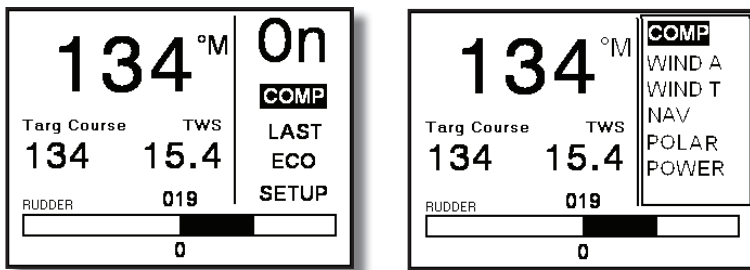

PILOT SCREEN ▼ highlight mode \downarrow ▲▼ Select mode type \downarrow

Each mode of steering is described in the following pages.

Steer to Compass

(COMP)

Steer to Compass is available with all Pilot configurations and is the basic method of Pilot steering. The boat is steered on the desired compass heading and the Pilot is engaged with a single key press.

The Pilot will steer using heading data either from a Halcyon 2000 Compass connected to the Fastnet databus, a Halcyon Gyro Stabilised compass connected directly to the Pilot ACP processor, or from other system sources.

The Pilot Target will show your target course (Pilot Course)

Steer to Apparent Wind Angle (WIND A)

This mode of steering is available to sailing boats that have a H3000 System fitted with a masthead Unit.

When WIND A is selected the Pilot will steer a course that maintains a pre-defined Apparent Wind Angle (AWA). If the wind shifts, or the boat moves off course, the Pilot will alter course so that the AWA remains the same.

The Pilot Target will show your desired AWA(Pilot AWA)

In general this works well when sailing upwind. For downwind steering to TWA may often prove more efficient.

Steer to True Wind Angle (WIND T)

This mode of steering is only available to sailing boats that have H3000 system fitted with a masthead unit.

When WINDT is selected the Pilot will steer a course that maintains a pre-defined True Wind Angle (TWA). If the wind shifts, the Pilot will alter course so that the actual wind angle remains the same.

The Pilot Target will show your desired TWA (Pilot TWA)

This mode is particularly effective when trying to maintain a steady wind angle downwind when the boat tends to change speed significantly on waves.

Steer to Waypoint (NAV)

This mode of steering is available to both sail and powerboats. It is available for Pilot systems that are using a H3000 Instrument system, interfaced with a compatible position-fixing device using NMEA 0183 protocols.

When engaged in NAV mode the Pilot will steer a course using waypoint data from the position fixer programmed with the waypoint positions.

It is important to remember that when the Pilot is steering to a waypoint using NMEA data, any erratic data or positional errors generated by the position fixer will be transferred to the Pilot via the NMEA interface and the instrument system. Position fixer errors can be due to many causes including: poor reception, bad satellite constellation, radio beacon chain transitions, local geography and high power transmitters.

Position fixer errors can cause steering inaccuracy. Always maintain a log and position plot on an up-to-date chart. Remember to check that the Pilot course (waypoint to waypoint) will steer the boat clear of any obstacles, taking into account the effects of tide and possible course errors.

Before using the NAV mode steer the boat manually until the XTE distance is less than 0.03 NM and the heading is close to the waypoint Bearing (Waypoint Course) as shown on the Pilot Display.

If XTE is more than 0.03 NM when the Pilot is engaged in Steer to waypoint mode, the course will be altered by up to 30° to bring the boat back onto track.

The Pilot Target will alternate between your bearing to waypoint (BTW) and cross track error (XTE)

Caution: *Before using NAV mode, check the following points:*

The position fixer has a compatible NMEA 0183 interface set-up in accordance with the manufacturer's instructions. The appropriate NMEA sentences are selected and set to be transmitted. The minimum data requirement is XTE (cross track error); however, XTE and BTW give the best steering performance. For Pilot operation select any of the following NMEA sentences: RMB (best option), XTE, APA, or APB together with BWR or BWC.

The position fixer is switched ON and has the correct current position.

The signal and noise levels are within the manufacturer's recommended limits.

The waypoints have been entered correctly, and the waypoint arrival alarm is switched ON.

If using waypoints in a route or sail plan, the waypoints have been entered correctly and in the correct order, the direction of the route has been selected and the route is enabled.

Steer to Target TWA

(POLAR)

PERFORM

Polar mode steers the boat to the Target TWA, this feature is available to sailing boats using the H3000 Hercules Performance CPU.

Data from the H3000 polar tables, stored in the H3000 Hercules Performance CPU allows the boat to sail at the Target TWA and is particularly useful for achieving maximum VMG (Velocity Made Good) upwind or downwind

The Pilot Target will show your Target TWA

Power

(Manual Steer)

Power steer is available with all Pilot configurations, and allows the helmsman to directly control the rudder using either the GPD keys or the Hand-held Controller. When in Power Steer mode, the Pilot control software is by-passed and the key operations directly control the rudder drive unit.

Power steer can be used in an emergency if the normal manual steering linkage becomes defective.

RESPONSE MODE

The Response Mode controls the response of the steering. Different selections are available dependent on whether the heading source is from the Halcyon Gyro-Stabilised Compass, or from standard heading source.

Response Mode: Halcyon Gyro-Stabilised Compass

NORM ~ Normal course keeping and rudder response (default).

ECON ~ Economy: The rudder movement is limited, this reduces the overall power consumption of the Pilot system, however there is a slight reduction in course keeping.

PERF 1 to 4 ~ Performance: Rudder movement is increased to give added course keeping performance at the expense of additional power consumption.

Of the four PERF settings, PERF 1 is the minimum setting and PERF 4 is the maximum.

Response Mode: Halcyon 2000 Compass or Other Sources

NORM ~ Normal course keeping and rudder response (default).

ECON ~ Economy: the rudder movement is limited, this reduces the overall power consumption of the Pilot system, however there is a slight reduction in course keeping.

DWIND ~ Down wind: The response is changed for down-wind steering by applying the rudder more quickly. This allows the Pilot to hold a better course in adverse conditions, such as sailing down-wind or with a quartering sea. However there is an increase in the power consumption.

ECON consumes the least amount of power when steering and offers the slowest response time consumes the most power and has the highest response time down wind.

ACTION

The action field will be populated with the relevant available action associated with the steering mode.

To implement the action, highlight the action on the Pilot screen press **↵** select **YES**, press **↵**. The action will be implemented immediately.

▼ Highlight the **ACTION** field **↵** Highlight **YES** **↵**

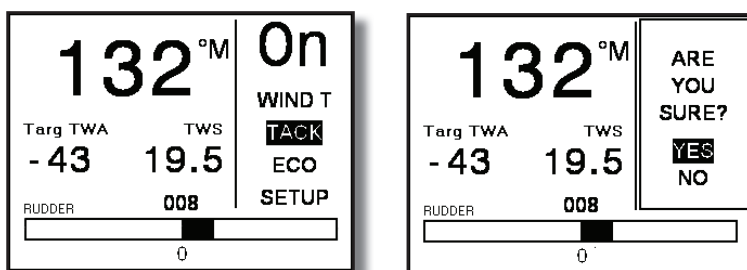

Mode	Action	Description
COMP	LAST	Last Course
NAV	NEXT	Next Waypoint
WIND A & T	TACK	Tack on Command
WIND A & T	GYBE	Gybe on Command
POWER	MID	Return to Original Position

LAST

In compass mode (COMP) As soon as you use the °10 left or right dodge keys to change course LAST will be shown in the action field.

When the boat is dodged 10° or a combination of 10° key presses the last course is kept in the Pilots memory and LAST will appear in the action field.

Highlight the field as shown in the action example and press Enter.

Select Yes and press Enter. The Pilot will return the boat to the last course.

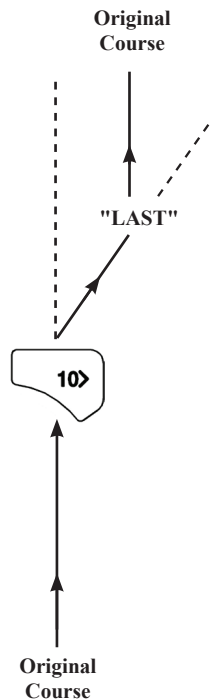

NEXT

In navigation mode (NAV) NEXT is shown in the action field as soon as you reach each waypoint.

Selecting NEXT will change your course to head towards the next waypoint. As the boat passes waypoint 2 NEXT will appear in the action field.

Highlight the field as shown in the action example and press

Select Yes and press enter. The Pilot will steer the course to the next waypoint.

WARNING: *If no action is taken the boat will continue on its current course.*

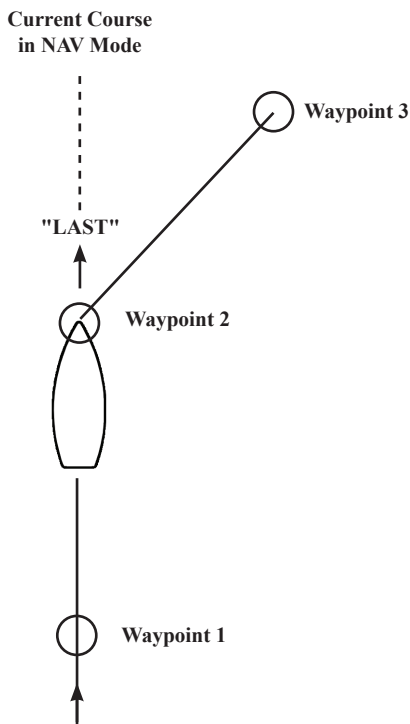

TACK & GYBE

In WIND A & WIND T modes depending on whether you are sailing upwind or downwind you will be given the option to TACK or GYBE in the action field.

As shown in the diagram, when sailing upwind TACK will be shown in the action field. The tack option is available up to 90° TWA.

When sailing downwind GYBE will be shown in the action field. The gybe option is available from 120° to 180° TWA

Between 90° and 120° the action field will remain blank.

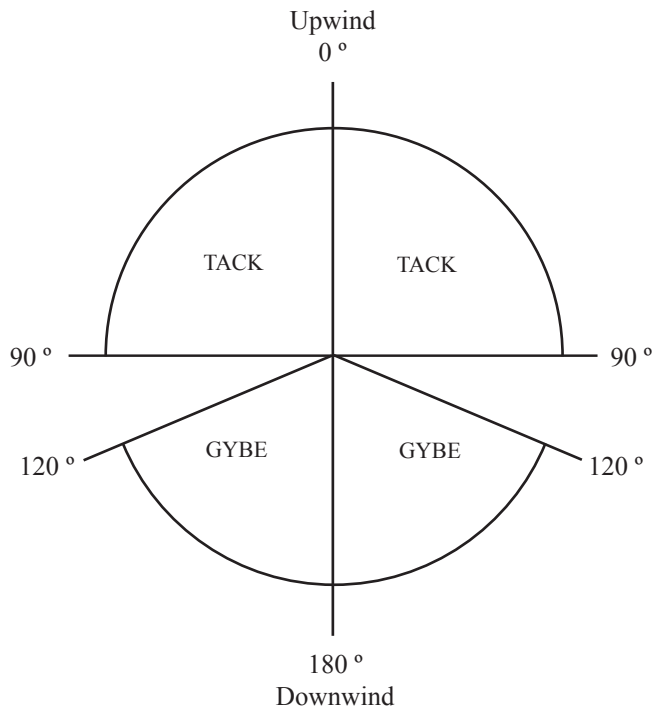

MID

In POWER mode MID is shown in the action field at all times.

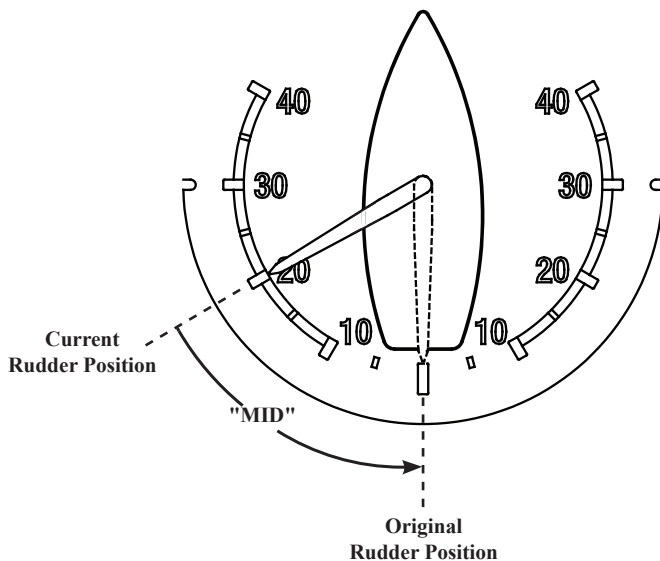

When you manoeuvre the boat in power mode via the GPD the rudder will move from the original rudder position, which keeps you on a straight course. To return the rudder to this position highlight the field as shown in the action example and press ↵.

Select Yes and press ↵. The Pilot will then return the rudder to the original position.

SETUP

Setup takes you directly to Advanced Settings. See page 64 for details of these settings and how to update and modify them.

COMMISSIONING

Before the H3000 Pilot can be used, it is necessary to carry out some commissioning procedures. This encompasses the setting and calibration of various parameters, installation and functional checks of the Pilot equipment. These items are listed below.

The procedure for commissioning can be divided into two stages. The first stage is carried out alongside at the dock and the second stage is performed during the course of a sea trial. The order in which the commissioning procedures are carried out is not the order in which they appear in the menu.

This manual covers both the ACP 1 (25A) and ACP 2 (40A) Pilot Systems.

PILOT INSTALLATION CHECK LIST

The checklist below should be used before the commissioning of the Pilot to ensure that the entire system is functional before applying power.

Drive Unit and Steering System

Drive unit securely fixed to a rigid part of the boat structure.

Correct gauge of power cable has been selected.

Hydraulic Rams

Mechanical end stops must limit the rudder movement, not the stroke of the hydraulic ram.

Split pins and spacers that secure the ram to its mounting foot are secure.

Absence of oil leaks.

Correct diameter bolt in universal ball joint, correct size hole in tiller.

Ram free to move side to side and up and down throughout the rudder travel.

Oil reservoir is at the highest point if external to the Ram.

Hydraulic Pumps

Pump unit is shielded from the direct effects of the elements.

Minimise the lengths of the hydraulic lines from the pump to the cylinder and where possible the pump motor supply cables.

Absence of oil leaks.

Absence of air in the hydraulic system.

Rotary Drives

No backlash or excessive slackness in chains/linkages.

Rudder Reference Installation

Base securely fixed to boat structure.

Arm securely fixed to boss.

Ball joint securely fixed to arm.

Linkage has not been over extended.

No slack or backlash in the linkage.

Linkage does not foul when rudder moved hard over to hard over.

Arm moves through at least 90° when rudder moved hard over to hard over (there must be at least a 1.0V difference between the end stops).

Ball joint securely fixed to quadrant/tiller.

Compass Installation

Mount the unit according to the installation guidelines.

Fitted as near to centre of motion of boat as other factors allow, aft of centre preferred as there is usually less motion than forward of centre.

A safe distance from external magnetic interference: 1m/3ft from VHF, loudspeakers, depth sounders, engines, power cables carrying heavy current, etc., 3m/(10ft) from radar and SSB equipment. Check the other side of bulkheads.

Electronics Installation

Cables secure.

Cables undamaged.

No loose bits of wire.

Screens connected in accordance with wiring instructions and sleeved where appropriate.

Parameters to be Set

The following is a list of the parameters that have to be set during commissioning.

These parameters must be set and configured prior to using the Autopilot.

Parameter	Page No.
Boat Type: Select Sail, Power Planning or, Power Displacement	56
Compass Swing: Compass deviation correction	31
Heading Source: Compass data selection	35
Heading Offset: Compass alignment correction	31
Magnetic DIP angle compensation	68
Rudder drive type selection	57
Rudder end stop Port position	57
Rudder end stop Starboard position	58
Rudder Mid position	58
Rudder hard over time	58
Speed sensor calibration	69
Boat waterline length in meters	70
Boat Lag value	64
Rudder Gain value	62
Watch alarm lock – Disables alarm ON/OFF control	71

PILOT COMMISSION

Dockside Setup

The following parameters must be set and configured before leaving the dockside.

When you leave the dockside follow the sea trial instructions before using the Pilot.

SETUP ► COMMISSION ► PILOT ►

Step 1 ~ Select Dockside Setup

► Highlight Dockside Setup ◀

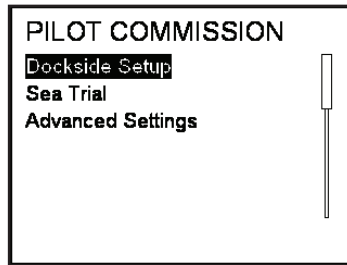

Step 2 ~ Select the Boat Type that the Pilot is fitted to.

► SET BOAT TYPE ▼ Select Boat Type ◀

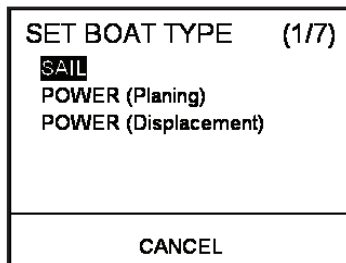

Step 3 ~ Select the Drive Type that is fitted to the boat. This information should be available in the documentation that was supplied with the vessel. We recommend that a visual confirmation of this is made before proceeding.

▶ SET DRIVE TYPE ▼ ⏏

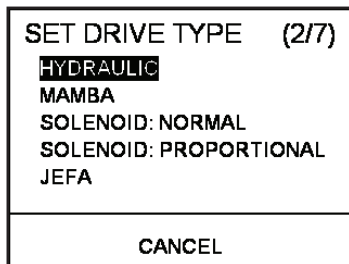

Step 4: Turn rudder hard to port so that the wheel is turned until the rudder gets to its physical end stop. This enables the Pilot to know its maximum possible extent of the rudder travel.

▶ TURN RUDDER HARD TO PORT ▼ OK ⏏

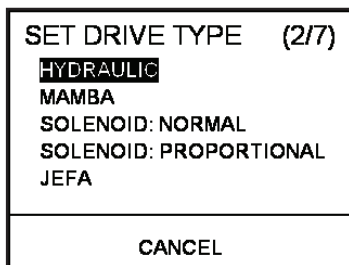

Step 5 ~ Turn rudder hard to starboard so that the wheel is turned until the rudder gets to its end stop. This enables the Pilot to know its maximum possible extent of the rudder travel.

► **TURN RUDDER HARD TO STARBOARD** ▼ ↵

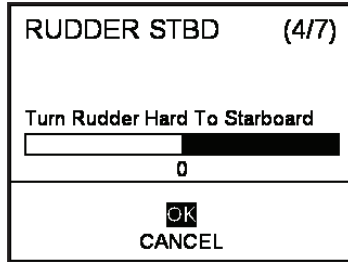

Step 6 ~ Set the rudder to the mid position. This stores the rudders mid position. This is reset during the sea trial so absolute accuracy is not critical at this stage.

► **SET RUDDER MID POINT** ▼ ↵

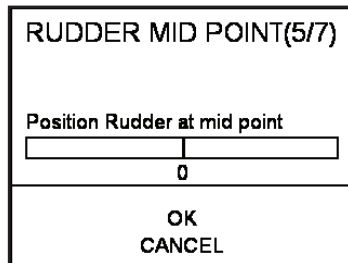

Step 7 ~ Start hard over time test. This will turn the rudder hard to port then hard to starboard back to port and then return to the mid position.

WARNING ~ Stand well clear of the boat wheel as in many cases this will turn as the rudder is moved from side to side.

► **TEST RUDDER HARD OVER TIME** ▼ **START TEST** ↵

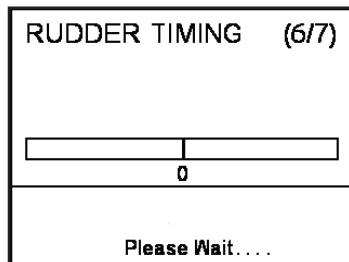
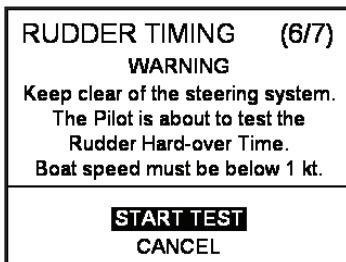

Step 8: Set the waterline boat length. This is the length of the boat in the water from stern to bow. Highlight each number individually and modify using the up and down keys ▼▲ Set the boat length in meters ↵

► SET WATERLINE BOAT LENGTH ▼▲◀▶ ↵

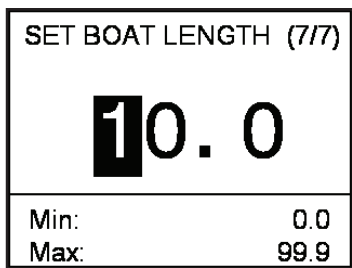

After you have set the boat length dockside commissioning is complete. Select OK to return to normal operation.

► DOCKSIDE COMMISSIONING IS COMPLETE ▼ OK ↵

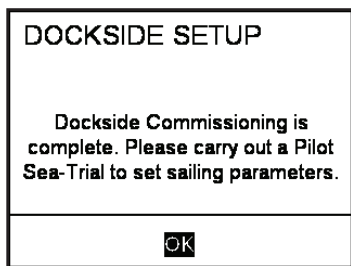

SEA TRIAL

Before using the Pilot the following parameters must be set and configured during a sea trial.

SETUP ► COMMISSION ► PILOT

Step 1 ~ Select Sea Trial

SEA TRIAL ⌵

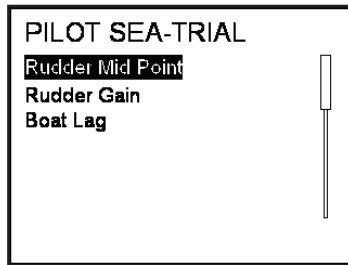

Step 2 ~ Set Rudder Mid Point.

Steer the boat manually under motor at a speed no greater than 15 knots. Head towards a landmark and maintain a straight course.

The rudder bar may well show a slight deviation from the centre line that was set at the dockside. When you are happy that you are on a straight course highlight OK without moving the wheel and press ⌵ This will reset the rudder mid position to zero.

▼ **RUDDER MID POINT** ⌵

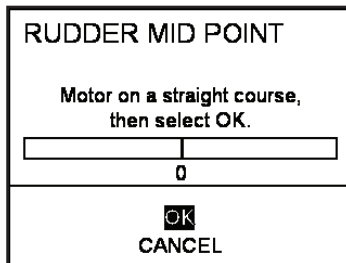

Step 3 ~ Set Rudder Gain

When the Pilot is part of an integrated system; boat speed data is supplied via Fastnet network from the H3000 instruments. By monitoring boat speed and rate of turn the Pilot will automatically 'learn' the correct value for Rudder Gain giving a rate of turn of approximately 6° per second for a sailing boat or 8° for a power boat.

If there is no direct speed input, or the speed source is set to manual, the Rudder Gain value must be entered manually; for these types of installations omit this section and proceed to Manual Rudder Gain below.

Checking Rudder Gain Learning

Steer the boat onto a suitable heading; allow time for the boat to settle on this course.

Engage the Pilot in Compass mode.

At a speed not exceeding 15 knots, make a minimum of 6 large course changes of at least 100° (ideally 170°) by multiple presses of the 10° course change buttons on any GPD or Handheld Controller. This enables the Pilot to learn the rudder gain value.

When the Pilot has learnt the rudder gain value the rate of turn will be approximately 6° (sail) or 8° (power) per second.

Press the Off Key to disengage the Pilot and return to manual steering.

Setting the Rudder Gain Manually

Steer the boat onto a suitable heading; allow time for the boat to settle on this course.

Engage the Pilot in Compass mode.

At a speed not exceeding 15 knots, make at least six large course changes of at least 100° by multiple presses of the 10° course change buttons on any GPD or Handheld Controller.

Observe and estimate the rate of turn. It should be approximately 6° to 8° per second.

Observe the performance of the Pilot when changing course. The rudder gain value is inversely proportional, therefore if the rate of turn is too SLOW, REDUCE the value of rudder gain and the Pilot will use more rudder. If the rate of turn is too FAST, INCREASE the value of rudder gain and the Pilot will use less rudder.

Adjust the Rudder Gain to give an average rate of turn of approximately 6° to 8° per second.

Rudder Gain Value		
Boat Type	Factory Set Value	Typical Values
Sail	2.0	1.0 to 3.0
Power	0.8	0.3 to 1.0

The factory set value is selected by setting Boat Type and Rudder Drive Type during commissioning.

Setting the Rudder Gain Value

The Pilot must be disengaged and in commissioning mode to adjust the Rudder Gain value.

▼ RUDDER GAIN ⌄ ◀▶▲▼ Adjust value ⌄

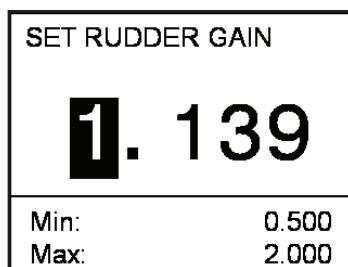

WARNING ~ When manually changing Rudder Gain use small increments (0-1) and test between each change. Very low values can cause steering instability.

Step 4 ~ Boat lag

Boat Lag is the time taken for the boat to respond to changes in helm. Heavy displacement hulls require a larger value for boat lag.

Checking the Boat Lag

At a speed not exceeding 15 knots, change course by 90o in either direction.

Observe the Pilot steering performance. The boat should turn onto the new heading with minimal overshoot (a slight overshoot is acceptable).

If the overshoot is consistently more than 5o for course changes in both directions increase the Boat Lag value in steps of 0.1 until the overshoot is corrected.

It is easier to spot overshoot than undershoot, hence if no overshoot is observed decrease the boat lag in steps of 0.1 until a small overshoot is seen. Use the smallest value of Boat Lag possible to minimise overshoot.

Boat Lag Response

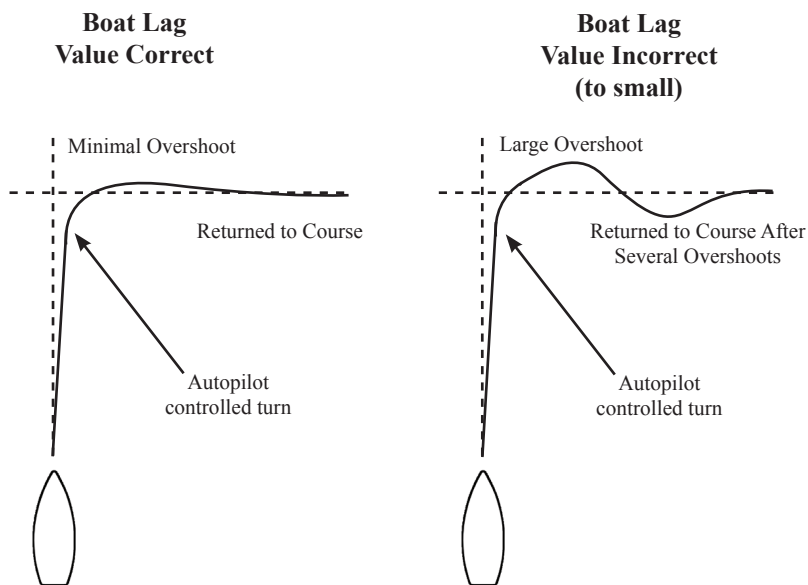

Setting the Boat Lag Value

▼ BOAT LAG ◀▶▲▼ Adjust value ◀▶

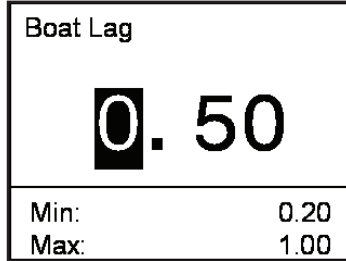

ADVANCED SETTINGS

These are optional settings that can be configured to optimise the performance of the Pilot. These settings are not essential for the Pilot to operate correctly.

SETUP ► COMMISSION ► PILOT ► ADVANCED SETTINGS

From the advanced settings menu you can access and modify the Pilot specific settings.

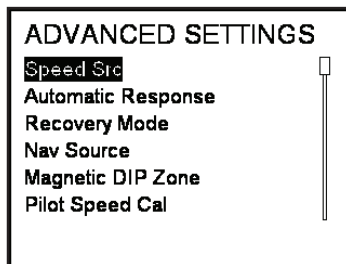

Speed Source

The Speed Source set-up allows the source used for speed data to be selected.

SET SPEED SOURCE	
BOAT SPEED	8.31
SOG	7.63
MANUAL SPEED	8.0

To select the desired speed source ▼ Highlight the required source ↵

When manual speed is selected you will also need to set the speed value. Use the ▲▼ keys to adjust the value in increments of 0.5 to the desired speed within the range 0.5 to 60.0 and press ↵

The default value for a sailing boat is 8.0 knots and 25.0 knots for a powerboat.

Automatic Response

This option is only available if a Halcyon Gyro Stabilised Compass is fitted.

The Auto Response set-up enables the Pilot to automatically alter the response level. There are four options available:

Off ~ The Pilot will always remain in the response mode selected.

Economy ~ The Pilot will need to sense large environmental changes before increasing the response setting.

Normal ~ The Pilot will respond to moderate environmental changes state before increasing the response setting.

Sport ~ The Pilot will be most sensitive to changing conditions and will automatically increase its response rate to counter environmental changes.

The Automatic Response mode will never reduce the response setting below the manually set value.

When the conditions have improved the Pilot will automatically return to the manual response setting.

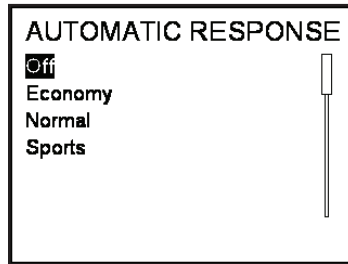

Recovery Mode

This function is only available when a Halcyon Gyro Stabilised Compass is connected to the system.

Recovery Mode allows the user to set the sensitivity to course errors. Pilot to react to unexpected events, for example sudden wave or wind shifts. This function allows the Pilot to instantaneously increase the steering response to its maximum setting (PERF 4), and make a rapid recovery.

The Recovery Mode will automatically switch off after 15 seconds or when the heading error has been corrected. The Pilot will then resume the previous response setting and continue normal operation.

There are four options available.

Off ~ The Recovery Mode function is switched off.

Narrow ~ The Pilot is most sensitive to sudden course changes corrected.

Medium ~ The Pilot is configured to the medium value when correcting sudden course changes.

Wide ~ The Pilot is least sensitive to sudden course changes.

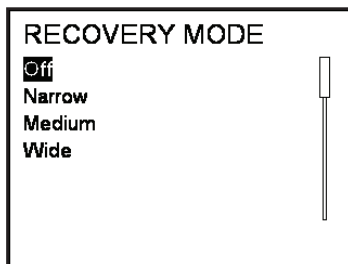

Nav Source

Nav Source allows the selection of a NMEA input on the system to use as the primary source of navigation data for the Pilot Steer to Waypoint mode. In most systems, where there is only one source of NMEA navigation data, this can be left on the default setting of zero which will automatically prioritise the navigation data from that source.

If you have more than one source of data it is necessary to enter the node address of the source you wish to use, normally this value will be for either the CPU (node 5) or a NMEA FFD (node 96, 97...).

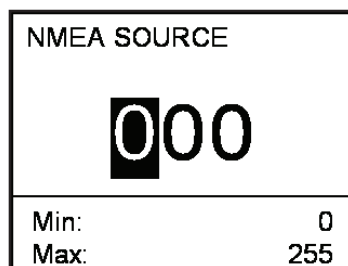

Magnetic Dip Zone

All magnetic compasses are affected by “northerly turning errors” in the northern hemisphere or “southerly turning errors” in the southern hemisphere, which increase with boat speed and magnetic DIP angle in higher latitudes.

These can cause heading instability at boat speeds greater than 20 knots when steering with a Pilot. By entering the dip value indicated on the compensation chart, the Pilot will be able to correct for these errors and improve the heading stability.

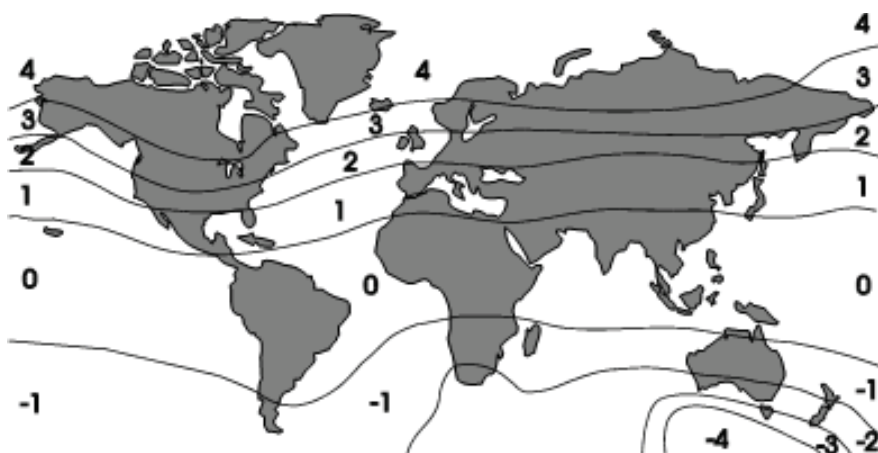

Select Magnetic DIP zone from the menu. Enter the value using the ▲▼ keys and press ↵ Use the minimum value necessary to stabilise the heading.

Note: This applies to boats faster than 20 Knots only.

Set DIP Compensation (°)	
0	
Min:	-4
Max:	4

Pilot Speed Cal

The ACP computer unit can take a direct speed input from a paddle wheel with a hall-effect output. Normally the Pilot uses boat speed supplied via the Fastnet network from the instrument system, this facility is only used when the installation does not include a compatible instrument system.

All B&G paddle wheel type speed sensors are compatible. The Hertz/Knot value is entered into the system to ensure the Pilot steering response is controlled with reference to an accurate boat speed. The default Hertz/Knot value is 3.80; this is the default setting for B&G speed sensors.

To determine if the value is correct compare the boat speed value displayed by the Pilot display (when the Speed Key is pressed) with the displayed value of speed on the log/speedometer fitted.

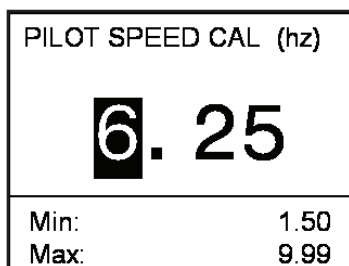

Setting the Speed Calibration Value

The speed cal reading is inversely proportional; i.e. to increase the boat speed, decrease the Hertz/Knot value.

Joystick Type

The joystick allows direct control of the rudder via the Pilot computer for quick and responsive steering. Joystick steering is engaged and disengaged with the separate Red Joystick Button. The lever can only be moved to port or starboard.

There are two joystick steering options available to the helmsman:

Normal Steering

The rudder moves in the direction of the joystick movement, when the joystick returns to the central position the rudder movement stops. The greater the movement of the joystick, the faster the response of the rudder.

Proportional Steering

The position of the rudder follows the position of the joystick. When the joystick returns to the central position the rudder returns to its initial position.

Joystick mode can only be engaged by using the Joystick Button. Select Normal or Proportional via the GPD by highlighting your selection and pressing . This is the mode that will be used when you engage the Pilot via the Joystick button.

When the Pilot is engaged in Joystick mode the rudder position at the moment of engaging will become the central (null) position of the joystick. To counteract any external influences on the steering, e.g. wind and tide, steer the boat on to a straight and steady course before engaging the Pilot.

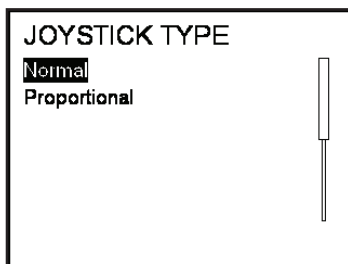

Boat Length

Use the ▲▼ keys to set the waterline length of your boat. Highlight each digit individually and change it accordingly. Press ↵ when this is completed.

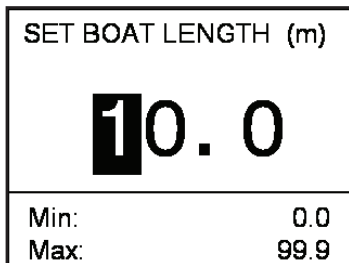

Rudder Max Angle

This sets the maximum angle of the rudder between 25° and 45°. The default angle is 40°. The angle should be set to match the physical value from centre line to rudder end stop on the boat.

Watch Alarm Lock

Watch Alarm Lock removes the ability to disable the watch alarm via the normal Alarms menu. The Watch Alarm lock must be unlocked before alarms can be disabled.

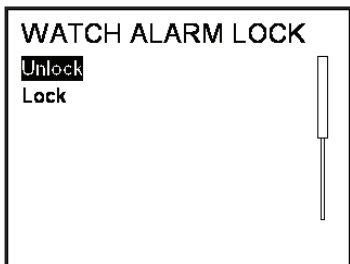

INSTALLATION INFORMATION

CABLE AND CONNECTION INFORMATION

EMC Compliance

B&G equipment is designed to be operated in leisure craft. Every care has been taken in the design and testing to ensure compliance with the European EMC Directive. Provided the equipment is installed and operated in accordance with the instructions supplied and the units and cables are used unmodified no problems should be encountered. Specific attention is drawn to the requirements to maintain cable separation, where stated. To comply with these regulations:

Ensure proper connection of cable screens

Transmissions from poorly installed or maintained Single Sideband (SSB) equipment may adversely affect the functioning of this equipment. On vessels fitted with an SSB, it is essential that such equipment be installed following good installation practice and as recommended by the manufacturer.

General Wiring Notes

CAUTION: *Do not apply power to the Pilot system until all units are connected and the wiring has been checked.*

Where spade connectors are supplied always use the correct crimping tool to attach them to the cable. This is extremely important where cables carry high currents, i.e. rudder drive unit supply cables (ACP 1 - 25 Amps or ACP 2 - 40 Amps).

Keep supply cables as short as possible to reduce voltage drop in the cables.

Always fit a suitable fuse or circuit breaker in supply cables. A 25 Amp (ACP 1) or 40 Amp (ACP 2) MCB is essential for the heavy-duty power cables.

Clearly identify each cable to prevent incorrect connection.

All cables should be routed at least 1m/(3ft) from cables or components that carry or generate high currents, e.g. alternators, starter motors and cabling, trim-tab cables, etc.

To minimise interference avoid routing Network cables alongside high power radio or Radar cables, allow 3m/(10ft) spacing, or within 1m/(3ft) of engine starter motors and cables and other cables carrying heavy current.

To prevent damage to cabling always secure in position using cable clips or tie-wraps. Where cables pass through bulkheads always protect the cable from chafing by installing grommets.

Do not allow cables to rest in the bilge where prolonged immersion in water, fuel etc. could occur.

Always fit splash covers and lids on processors, computer units and junctions boxes, where supplied.

Pilot Drive Unit Cables

All Rudder Drives - Heavy Duty Power Cables			
Cable Length	B&G Cable	Copper Area	Cable Gauge
Up to 8m (26ft)	135-0A-128	4.0mm ²	12 AWG
Up to 12m (40ft)	Not Available	6.0mm ²	10 AWG
Up to 20m (65ft)	Not Available	10.0mm ²	7 AWG

Rams and Rotary Drives - Clutch/Valve Cables			
Cable Length	B&G Cable	Copper Area	Cable Gauge
Up to 9m (30ft)	135-0C-096	0.5mm ²	22 AWG
Up to 15m (50ft)	135-0B-096	0.5mm ²	22 AWG

NETWORK INSTALLATION

The Fastnet network installation shown below should be installed in a linear fashion and ideally run in a line from one end to another with short ‘spurs’ to displays and processors etc. A ‘star’ network with many network spurs off one point will not work correctly, and must be avoided.

Example 1~ Two network cables. Processor switch to OFF. Terminated in the last junction box at each end.

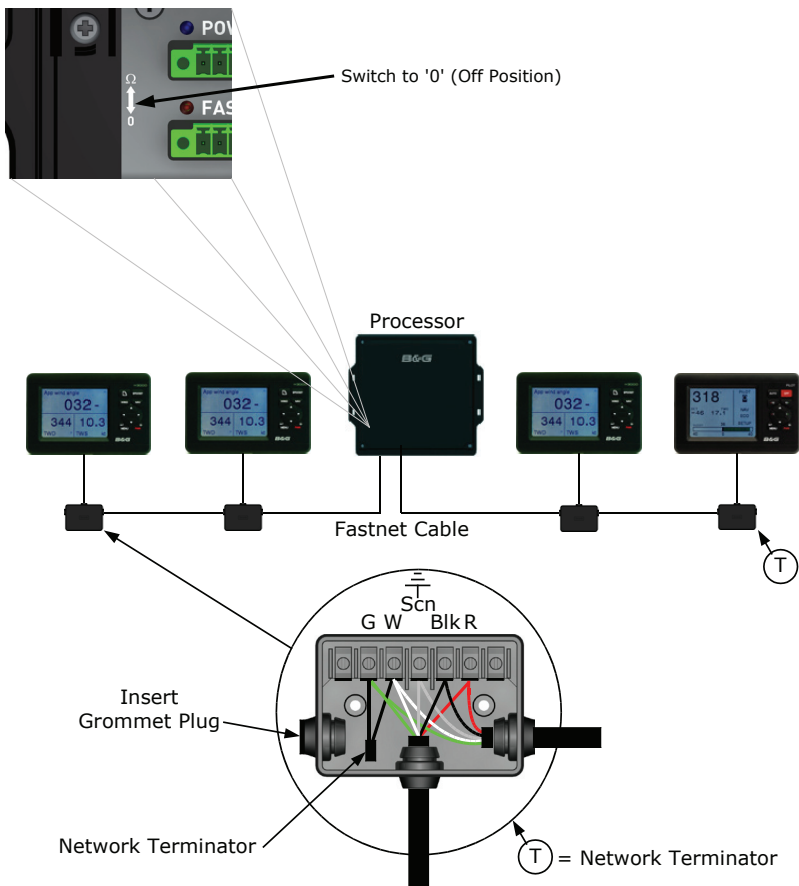

Example 2~ Single network cable. Processor switch to ON. Terminated at processor unit via switch as shown. Add a network terminator to the last junction box at the end.

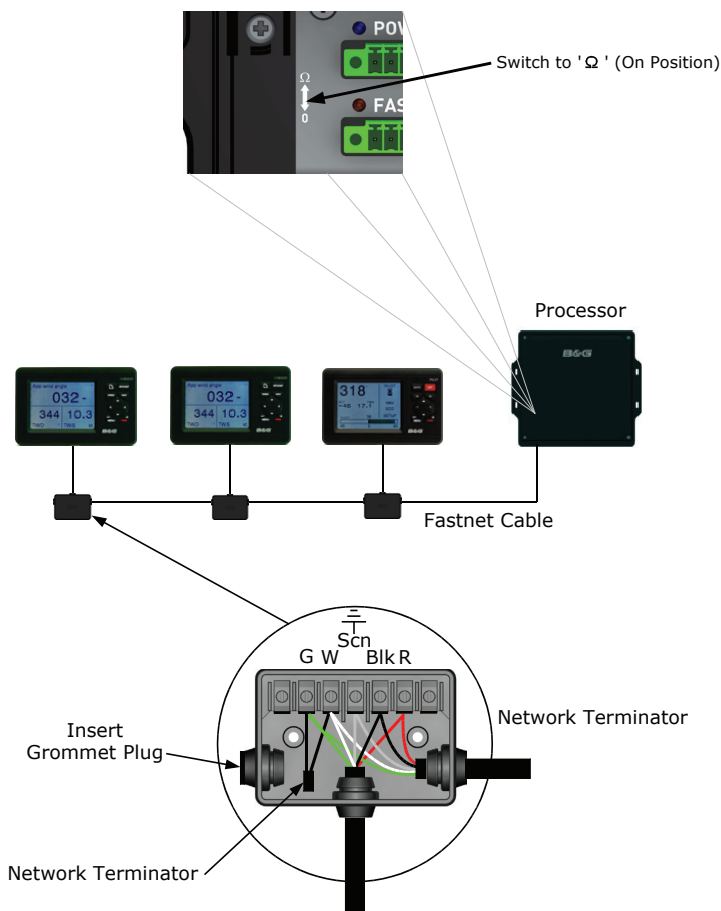

Note: A network terminator must be fitted across the green and white network data wires of the last unit or junction box at each end of the network cable. When adding more displays or units to the network, ensure that the terminator is moved to the ends of the network cable. Never fit more than two terminators on the network.



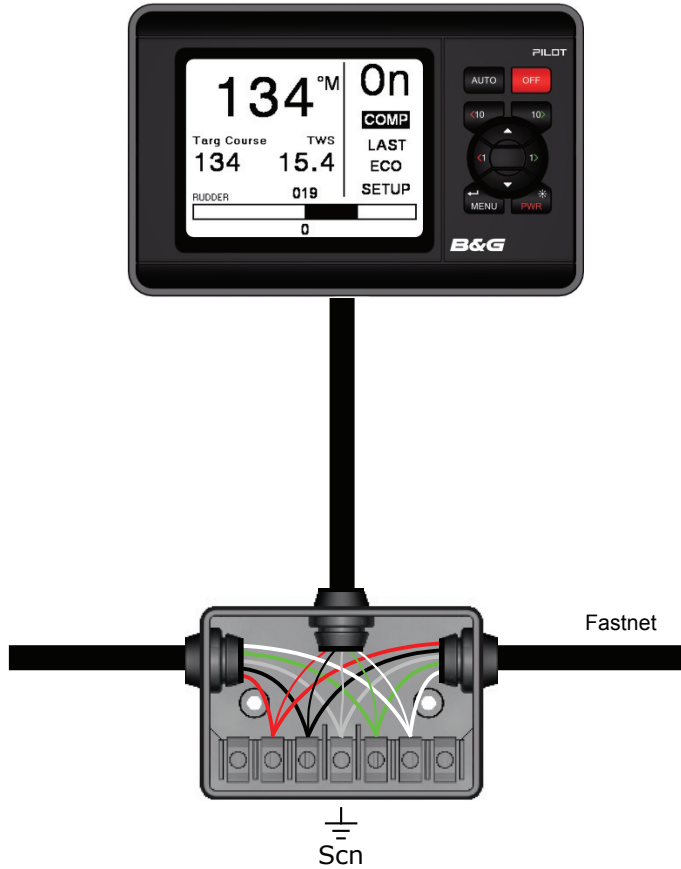





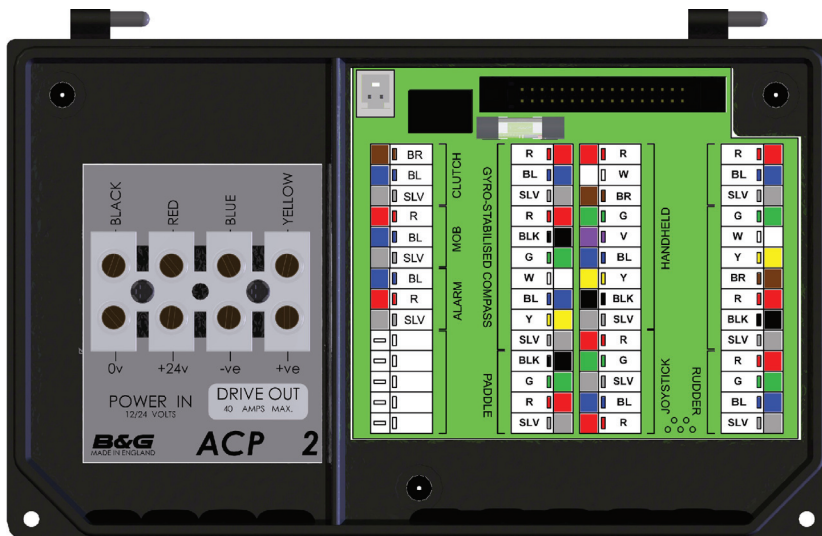

PILOT DISPLAY CONNECTIONS



GPD		
TERMINAL	COLOUR	FUNCTION
1	GREEN	Network Data -ve
2	WHITE	Network Data +ve
3	SHIELD	Network Cable Shield
4	BLACK	Ground
5	RED	Supply +ve (Normal 12V)

ACP UNIT TERMINAL DETAILS



Wire Colour Coding/Abbreviations		
	BLK	Black
	BL	Blue
	BR	Brown
	G	Green
	R	Red
	SLV	Silver
	V	Violet
	W	White
	Y	Yellow
	Blank	Not Used

Clutch Voltage Selection

The ACP computer unit can output different clutch/solenoid voltages depending upon the size of the rudder drive unit fitted. The clutch/solenoid valve is only required for rams or rotary drive units. This is achieved by setting dip switches on the computer drive PCB in the lid of the computer unit.

Set the switches as per the table below. The default setting is 9V, (switch 4 ON) suitable for size 1, 12V rams and size 2, 12V rams.

ACP DIP Switch Selection		
DIP Switch	Clutch Voltage	Drive Size / Type
1	24V	24V Rotary
2	18V	Size 3, 24V Ram
3	12V	12V Rotary
4	9V	Size 1 & 2, 12V Rams

Note: *when using drives from another manufacturer, it is important to refer to the documentation supplied with that drive to determine the correct clutch voltage selection. Refer to the manufacturer of the drive for further information.*

DIP Switch Location

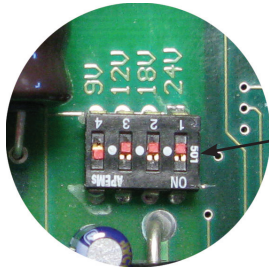

DIP Switches

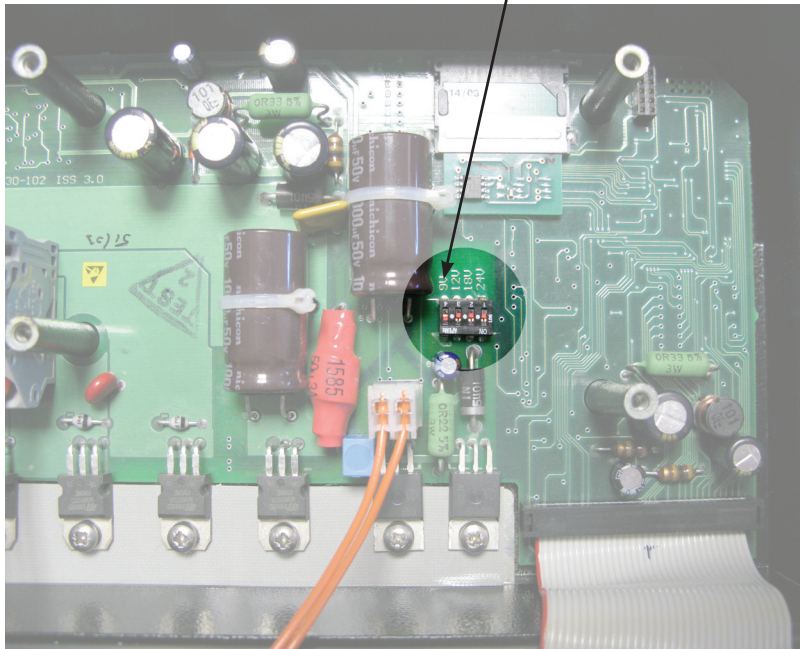

ACP WIRING CONNECTIONS

Network & Alarm

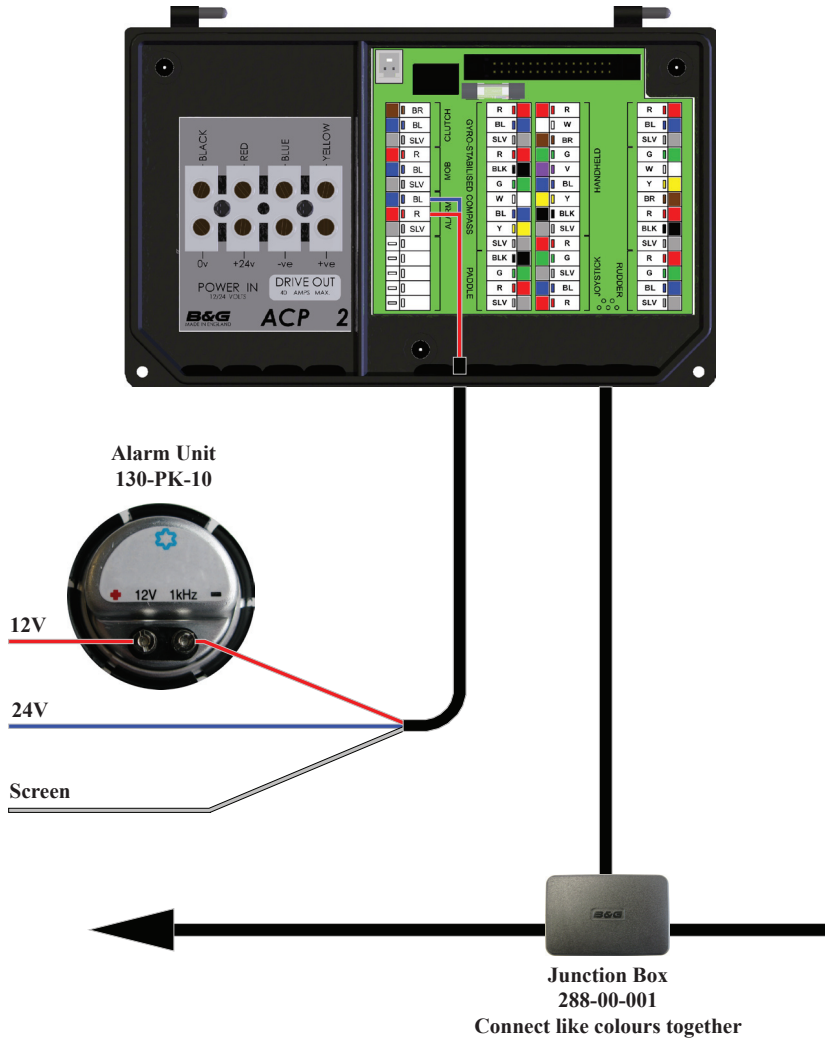

Note: The maximum rating for the alarm output is 12V, 20mA

Man Overboard Button & Hand-held Controller

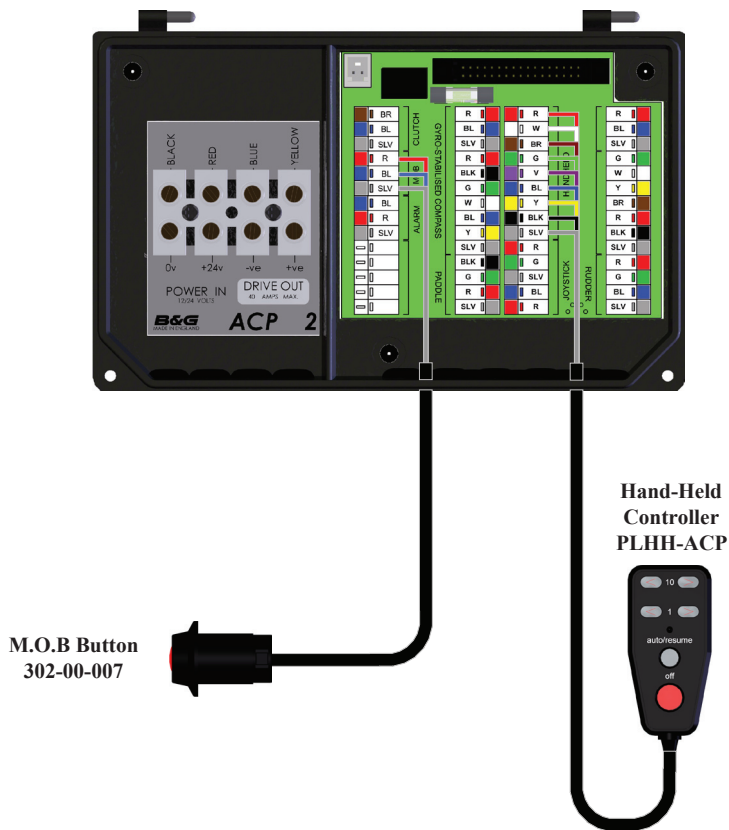

Remote Button & Joystick

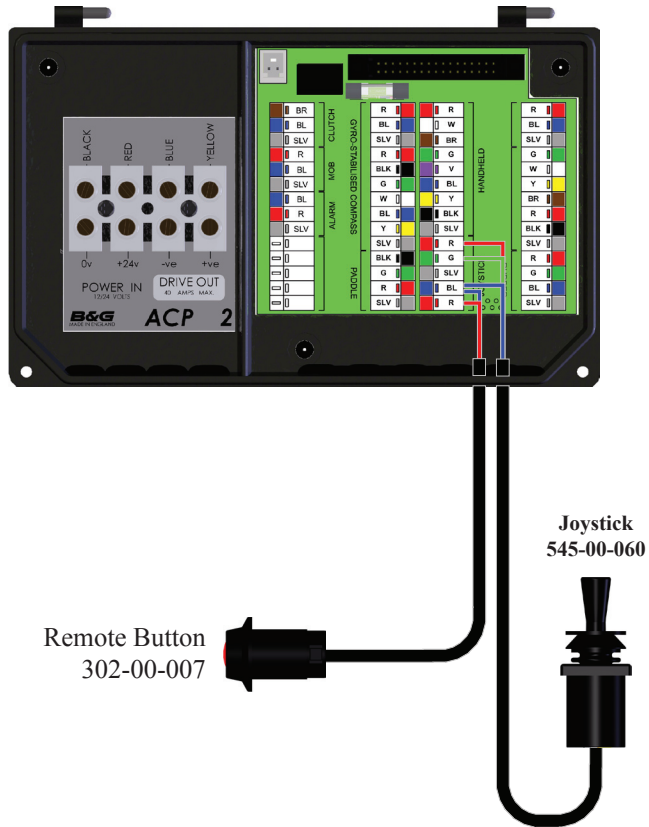

Hydraulic Ram Drives

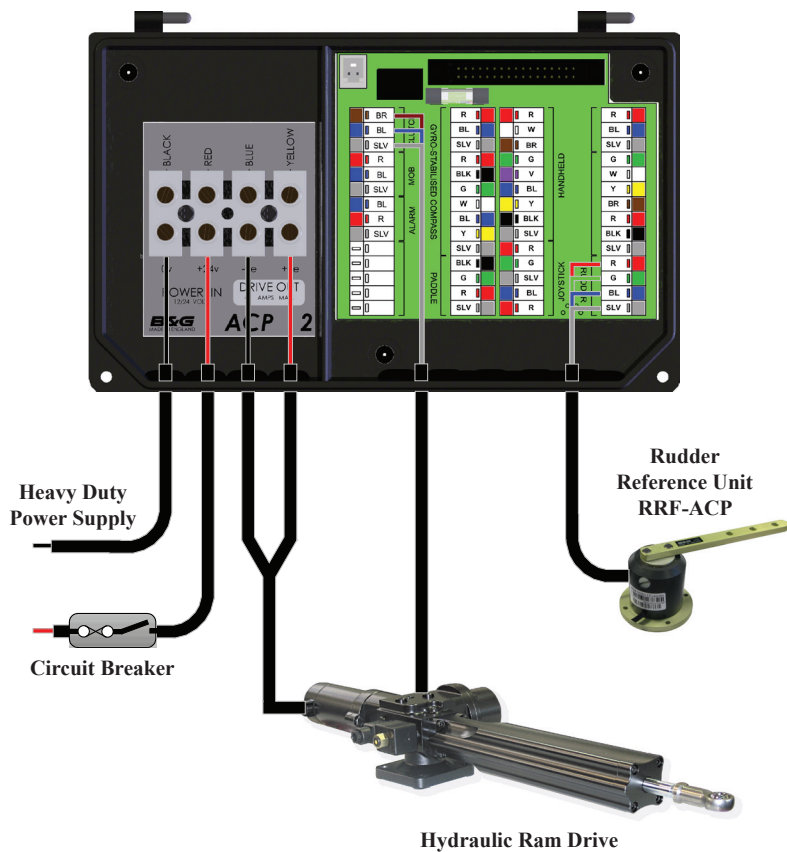

Rotary Drives

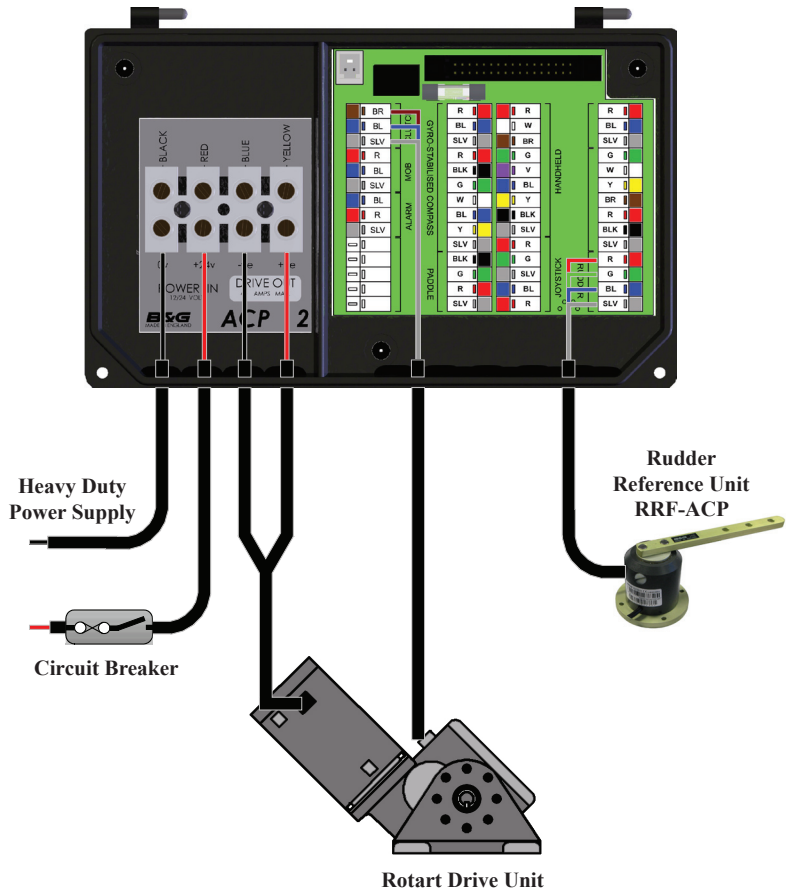

Stern Drives

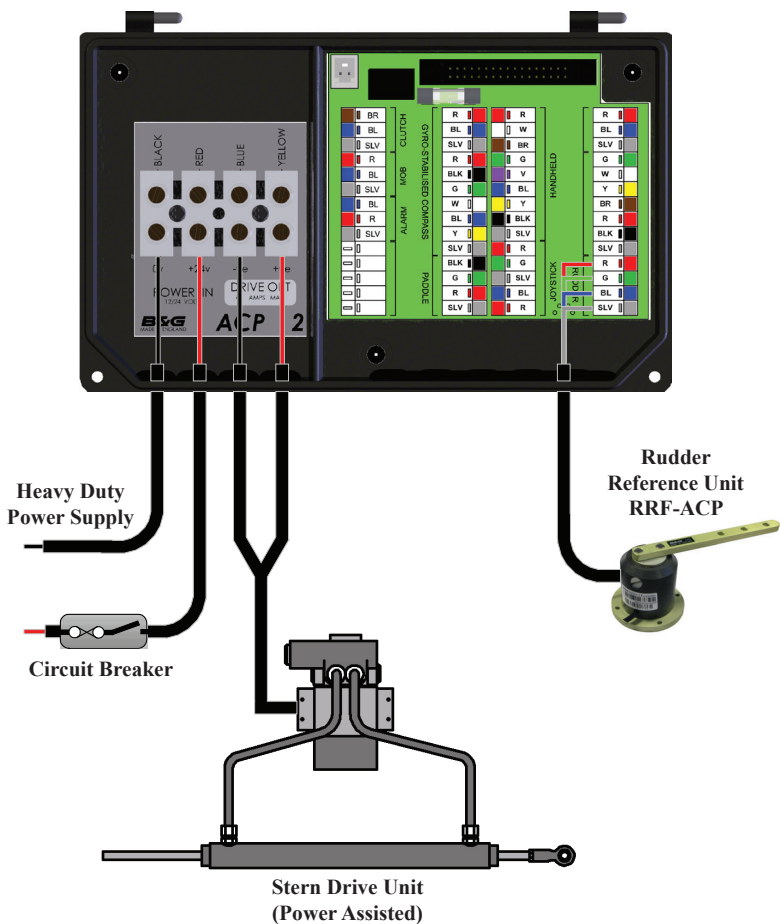

Proportional Solenoid

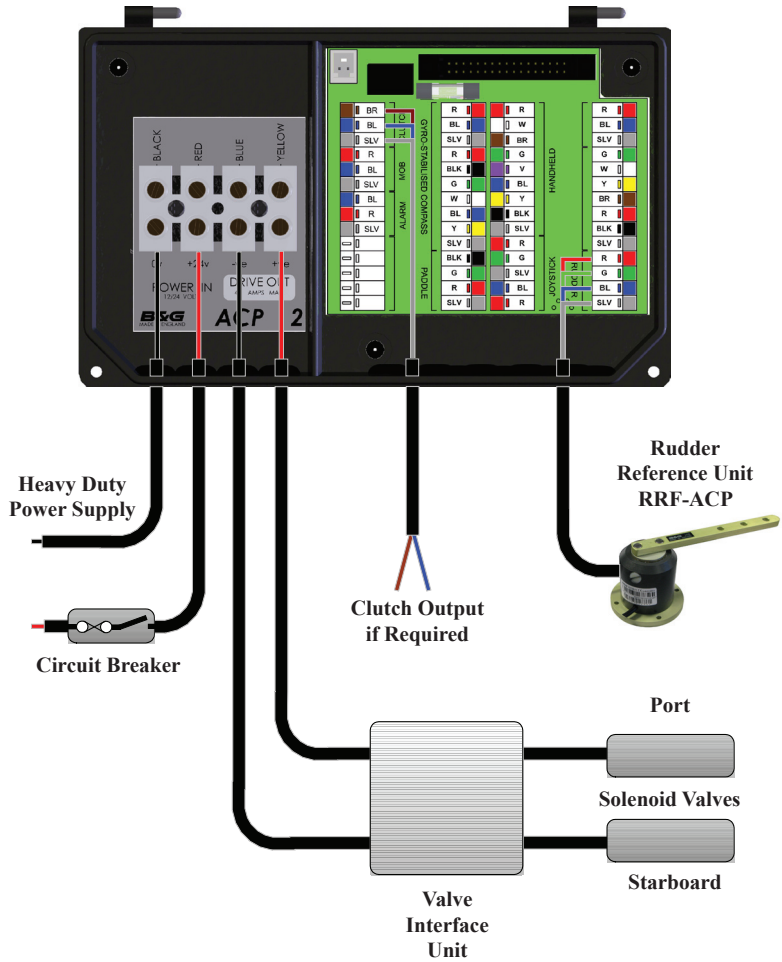

Continuous Drives

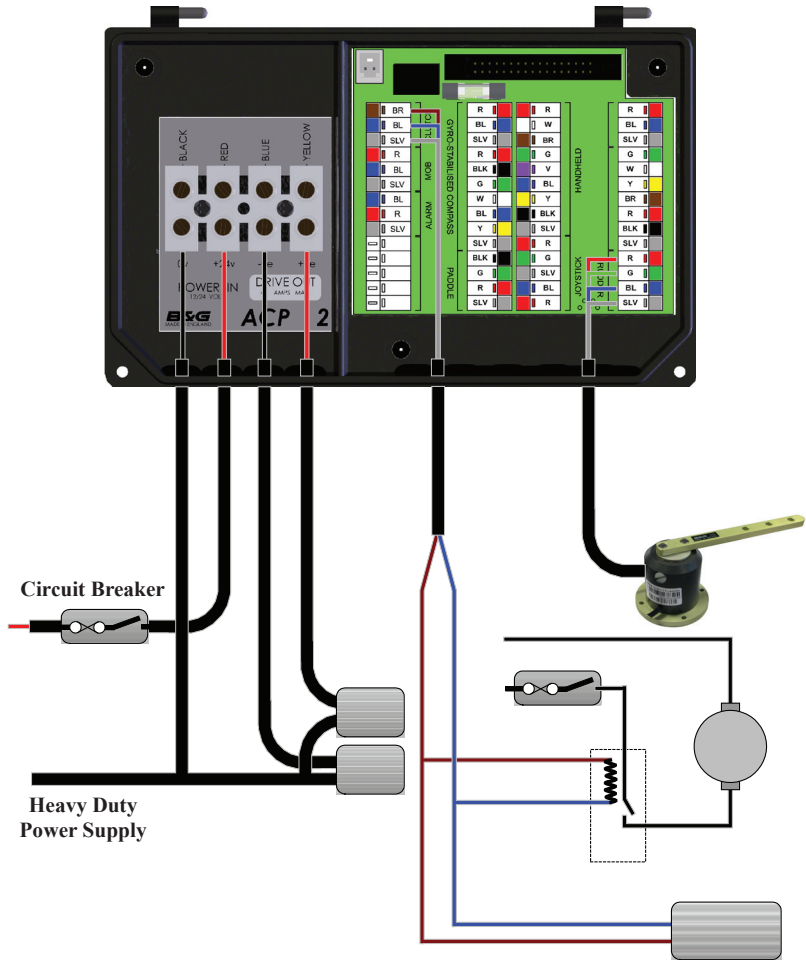

Linear Feedback

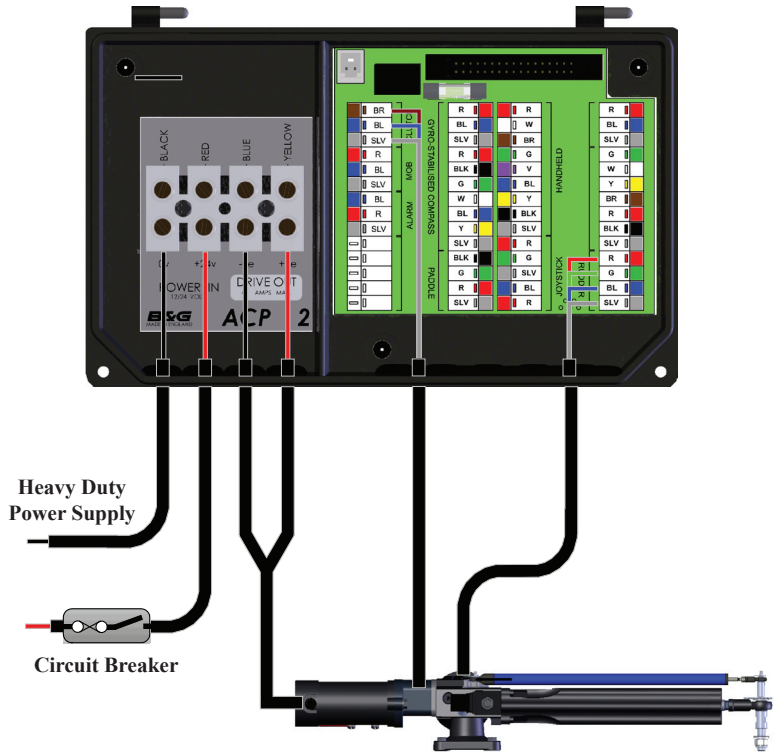

Halcyon 2000 Compass

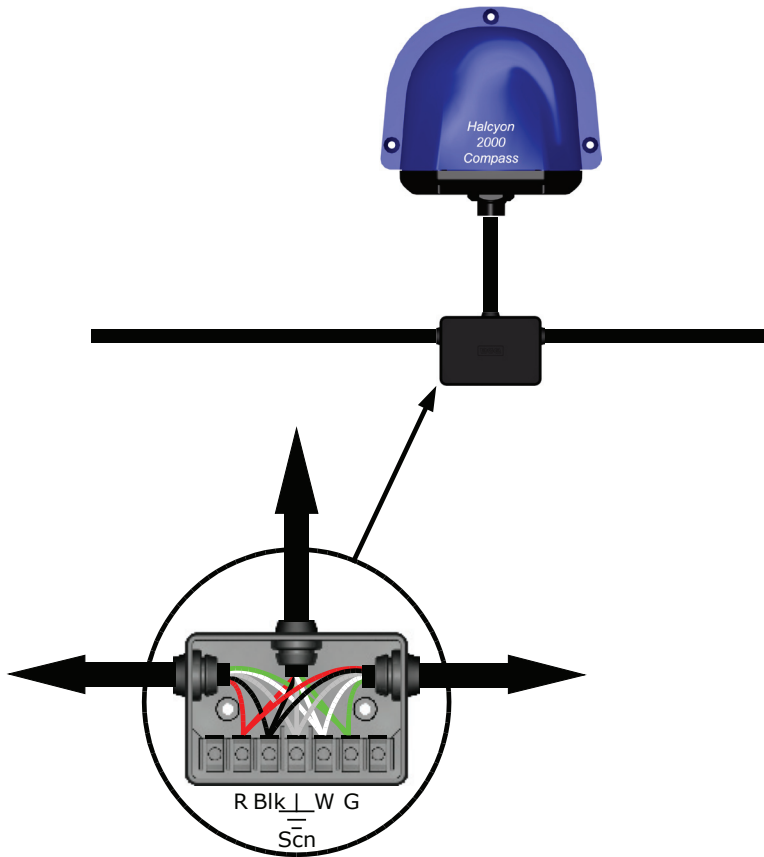

Halcyon Gyro Stabilised Compass

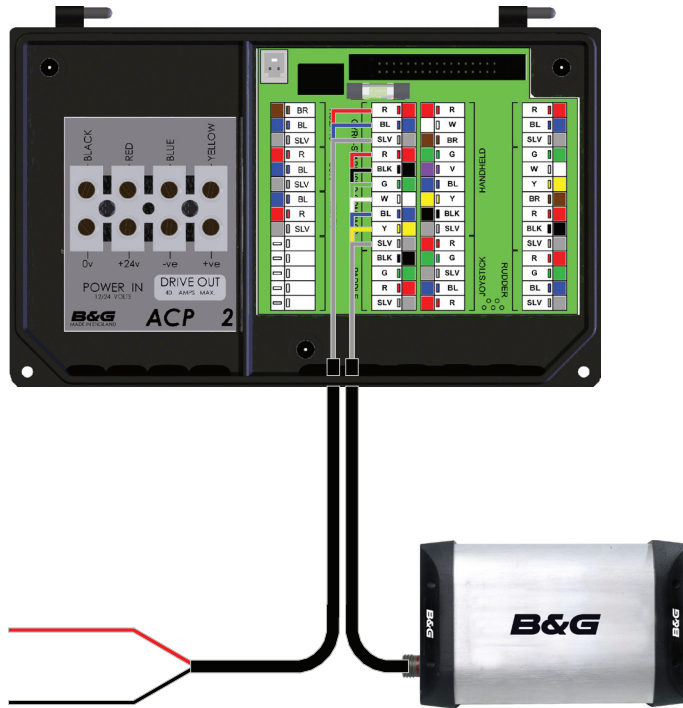

Direct Speed Input

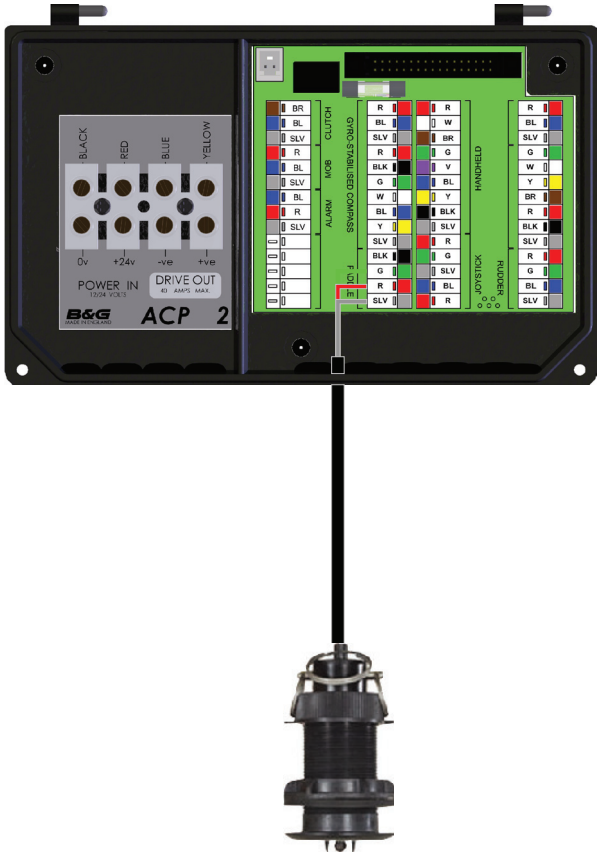

Direct Speed Input

You can use a non B&G speed sensor but it must have a speed signal output from a Hall-effect device giving positive pulses up to a maximum of 12V.

Locate the cable from the speed sensor to the instrument input, cut cable if necessary and insert a junction box. Connect like colours. Use a length of 2-core screened cable to connect the speed signal and ground of the paddle sensor to the speed input of the Pilot computer unit.

Calibrate the speed input in accordance with the instructions given in the 'Speed Source' section of the 'Advanced Settings' menu.



Non B&G Paddle Wheel Connection		
Pilot Computer Unit Boat Speed Terminals	Function	Cable 135-0B-098
Green	Speed Signal Input	Red Wire
Red	Not Used	Not Used
Black	Ground	Blue Wire
Silver	Screen	Screen

ROTARY RUDDER REFERENCE SENSOR

Installation of RRF

A number of key points must be considered for optimum performance of the unit:

Mount the unit on a flat surface next to the tiller arm or steering quadrant. Construct a small platform if necessary.

Do not lengthen the drag-link arm as this can transmit excessive vibration to the sensor.

The sensor operating arm can be rotated through 360°. The mid-point of the RRF wiper travel is when the arm is opposite the cable entry point. The sensor arm should be approximately opposite the cable entry point when the helm is in the mid-ships position.

When the rudder is moved hard-over port or hard-over starboard, the RRF arm should travel through a minimum angle of 90° to ensure sufficient voltage swing. Measure the voltage difference between the blue (0V) and green (signal) wires from the RRF; there should be at least a 1V dc change from port to starboard.

After fitting and connection of the RRF test the full movement of the steering gear to ensure no fouling occurs between the ram drive, steering gear and RRF.

Check for backlash in the linkages. Excessive backlash will cause errors in the operation of the Pilot.

The example opposite shows a plan view of a typical system with a tiller arm and quadrant. When viewed in elevation, the ram drive arm and rudder reference unit drag-link must not be more than $\pm 9^\circ$ from horizontal. Ideally, everything should be horizontally aligned as this prevents excessive stress during operation.

Typical System with Tiller Arm and Quadrant

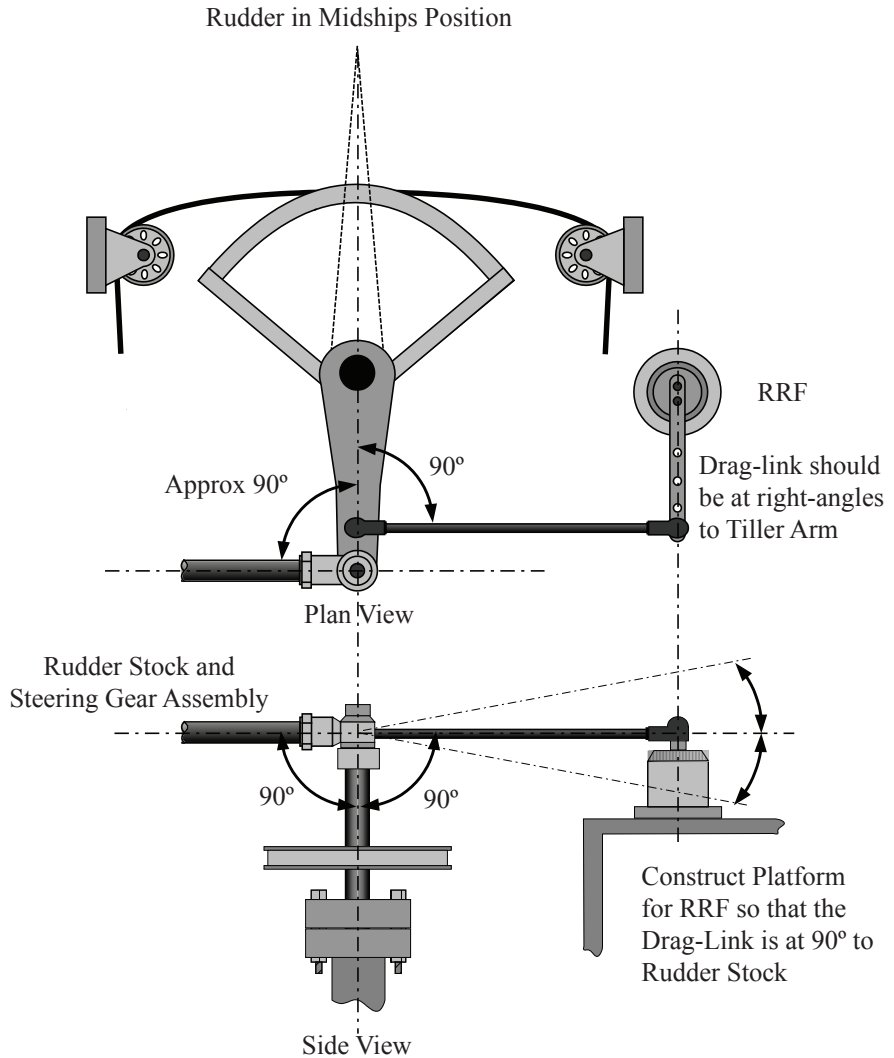

Steering System Orientation

The RRF can be mounted in many different positions and orientations depending on the layout of the steering system.

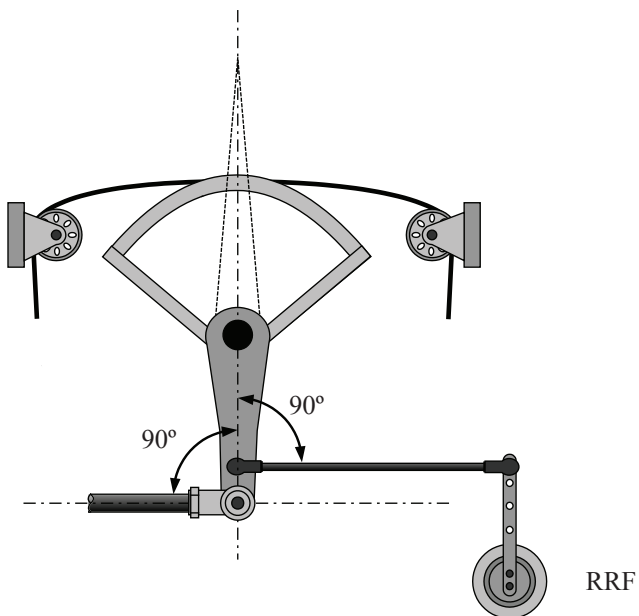
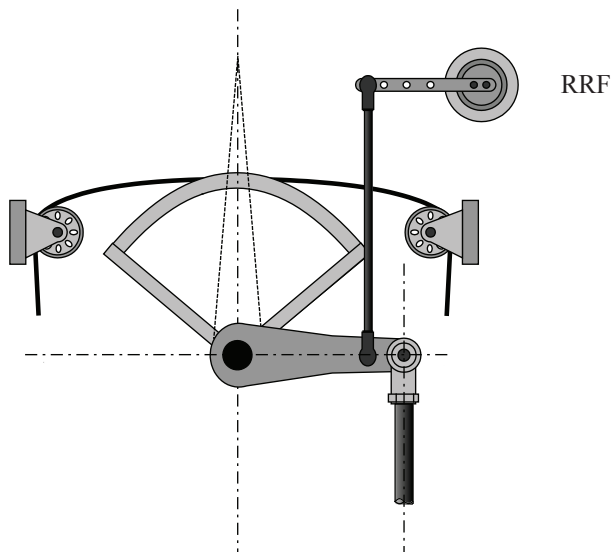

RRF Position

If the maximum rudder angle is less than 90° then the position of the RRF or the drag-link must be adjusted so that the operating arm of the RRF swings through a minimum of 90° and the output voltage difference is greater than 1 volt from port to starboard lock. Measure the output of the RRF between the green and blue wires.

Note: *If there is less than 1V dc difference, the Pilot will not commission.*

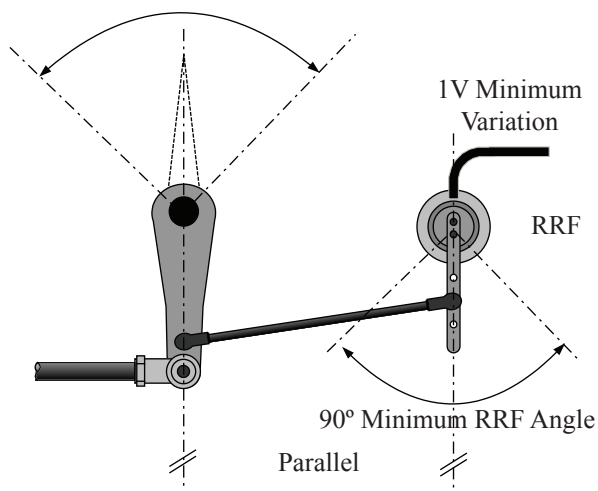

Drag-Link & RRF Position

The rudder hard-over angle should only be limited by the rudder stops and not the RRF linkage. Check that when hard-over the RRF arm and drag-link, do not form a straight line. If this occurs, the steering system could become damaged or jammed endangering the boat and crew. Rectify this immediately by adjusting the position of the RRF.

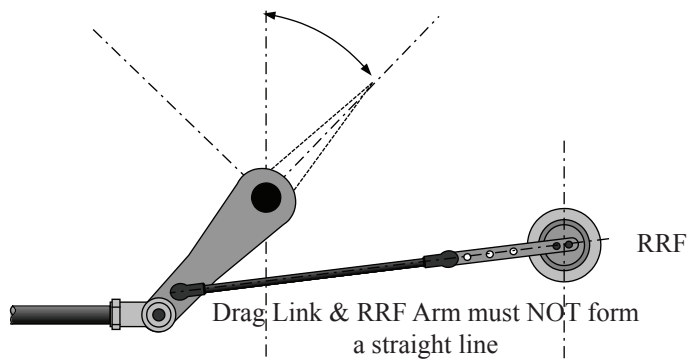

Linear Feed Back Unit

Where installation of the conventional rudder reference unit is difficult or physically impossible, a linear feedback unit (SEN-RUD-LFB) can be used.

The linear feedback unit comprises of a tube approximately 23mm (7/8 inch) in diameter and 300mm (12 inch) long. This assembly is attached to the top of the B&G Ram types 1 or 2. Each end of the linear feedback unit has a small ball joint that is attached to corresponding pillars on the ram; the ball joints are retained using washers and spring clips.

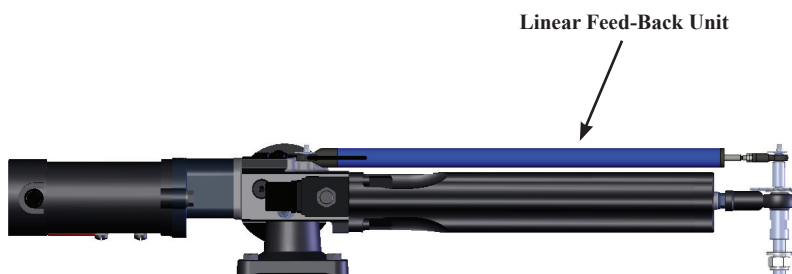

DIAGNOSTIC DATA

The Pilot computer is continually monitoring the Pilot and H3000 System for correct operation. If a fault is detected the Pilot Display will show an error message. If installed the system audible alarm will sound.

To remove the alarm window globally from all GFDs select down, then SILENCE and press '↵' if you wish to remove this warning from the display you are using only highlight IGNORE and press '↵'

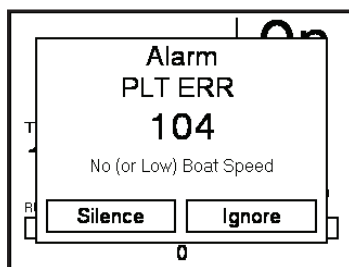

Error Messages	
Code	Description on GPD/GFD
100	Pilot not commissioned
101	Pilot compass failure
102	Rudder sensor out of range
103	Rudder drive not responding
104	No (or Low) Boat speed
105	System compass failure
106	No NMEA Date
107	<NOT USED>
108	Poor quality NMEA data
109	No (or Low) Wind speed
110	No optimum wind data
111	Current trip: Drive or Clutch
112	Network communication error
113	Memory card changed - Reset end stops
114	Memory card error
115	Drive power failure - Check supply
NO PILOT	Network communication error - Cannot detect pilot computer

FAULT DIAGNOSIS

Fault 100 – Pilot not Commissioned

Fault Description

The rudder end stops on the Pilot have not been commissioned, or the memory has been corrupted.

Remedial Action

1) Has the Pilot ever been successfully commissioned?

Yes go to step (4)

No go to step (2)

2) Carry out the Dockside commissioning procedure (see page 56). Display the Pilot screen, move the helm, does the rudder indicator function?

Yes go to step (4)

No go to step (3)

3) The rudder indicator on the Pilot screen will not function if invalid rudder end and mid points have been entered. Check the rudder reference unit installation (see page 91) is such that the voltage difference between the port and starboard end stops is a minimum of 1.0 volt. After checking repeat step (2).

4) If the rudder has previously been successfully commissioned then the fault is likely to be due to memory corruption. This may be due to a recent change of software version or severe interference (e.g. lightning).

We recommend that you reset the Pilot computer (node 18) and attempt to re-commission the Pilot. If this fails contact your local specialist dealer.

Fault 101 – Pilot Compass Failure

Fault Description

No valid data is being received from the Halcyon Gyro-Stabilised Compass (HGSC) sensor connected directly to the Pilot computer.

Remedial Action

- 1) Is an HGSC sensor in use?
Yes go to step (3)
No go to step (2)
- 2) Ensure that the Heading Source is set to the correct value for the compass sensor in use.

SETUP ► COMMISSIONING ► HEADING SOURCE

- 3) Check all wiring connections to the compass unit. There should be both a sensor cable AND a 12V supply cable, see page 87 or 88

Fault 102 - Rudder Sensor out of Range

Fault Description

The signal from the rudder reference unit is outside the limits set during commissioning. This usually indicates either a worn sensor or loose components.

Remedial Action

- 1) Check installation of rudder reference unit for slack or loose fittings. Replace any worn parts and secure any loose items. If the position of any part has been changed it is necessary to follow the Dockside Commissioning procedure.
 - 2) Display the Pilot screen on a GPD, watch the rudder indicator carefully whilst turning the helm slowly from hard-over port to hard-over starboard. The indicated angle should change smoothly as the wheel is turned.
- If the indicator does not move at all follow the Dockside Commissioning procedure

- If the indicator is erratic move to step (3)
- 3) Check the voltage supply to the rudder reference is 4.5 to 5.0 volts.
- 4) Check the signal from the rudder reference with a voltmeter at the Pilot computer

With someone moving the helm slowly port to starboard (as in step 2) the voltage should change smoothly. If the signal is incorrect suspect a faulty rudder reference unit. Note: The difference between the signal voltages measured at the two end stops must be at least 1V dc.

- 5) If the fault always occurs at the same rudder angle, suspect a faulty rudder reference unit. If the fault occurs at different rudder angles suspect a fault in the wiring connections to the Pilot computer or a fault with the Pilot computer electronics.

Fault 103 - Rudder Drive

Fault Description

The Pilot attempted to move the rudder, but did not sense any change in rudder position or when the Pilot attempted to move the rudder, it moved in the wrong direction.

Remedial Action

If the fault occurs all the time when the Pilot is engaged:

- 1) Is the heavy-duty power supply circuit breaker for the Pilot drive switched on? If not the fault 103 message may be triggered alongside a fault 115 message (see below).
- 2) Move the helm. Does the rudder indicator work? if not check physical installation of the rudder reference unit as detailed above.
- 3) Select Power mode. If drive system includes a clutch or solenoid valve (normal ram drives and most mechanical rotary drives), engage the pilot and check the operation of the clutch or solenoid valve. It should not be possible to move the helm with the Pilot engaged.

If the helm can be moved (i.e. the clutch fails to operate) disconnect the clutch

from the Pilot electronics and test its operation when connected directly to the drive power supply.

- 4) With Pilot engaged in "Power Steer" mode use the 10° and 1° port and starboard keys to move the rudder. If the motor fails to run disconnect the motor from Pilot electronics and test the operation when connected directly to power supply.

If the fault occurs intermittently or under heavy loads:

- 1) Use power steer mode to move rudder while restricting movement by holding wheel. If the fault occurs under these conditions it could be due to:
 - Excessive motor current
 - Too much slack or backlash in drive or fixing to tiller
 - Air in hydraulic system

Check the physical installation of the drive system for these points.

Fault 104 - No (or Low) Boat Speed

Fault Description

The boat is travelling at a speed below 1kt or the speed sensor is not working.

If you are testing a Pilot at the dockside, or you require the Pilot to operate at very low boatspeeds, you should set the Speed Source to a manual speed, see page 65

Remedial Action

- 1) If the Pilot is taking boat speed from an instrument system check the speed shown on the instrument system display, if the instruments are showing an erroneous value then investigate the cause on the instrument system (fouled sensor etc.)
- 2) If the boat speed sensor is connected directly to Pilot check the wiring connections.
- 3) Check the functionality of the speed sensor, change the Speed Source from Boat Speed to SOG or Manual Speed if the paddle wheel sensor is inoperative.

Fault 105 - System Compass Failure

Fault Description

Heading data from an instrument system compass sensor has failed.

Remedial Action

- 1) Check the Heading Source is set correctly for the compass in use, see page 41
- 2) Check the heading data on the instrument system updates normally as the boat changes course.
- 3) Check the wiring connections for the compass sensor in use and the connection of the Pilot ACP to the Fastnet network.

Fault 106 - No NMEA Data

Fault Description

XTE data from the position fixer (e.g. GPS) via instrument system network has stopped.

Remedial Action

- 1) Check that the XTE data displayed on the instrument system is accurate and updating regularly.
- 2) Check the operation of the position fixer, if the device no longer has a position fix it is likely that the NMEA output has stopped. Refer to the troubleshooting guide in your position fixer documentation for further information.

Fault 108 - Poor Quality NMEA Data

Fault Description

The value of XTE data being received via the instrument system has suddenly changed by more than 0.3 nautical miles.

Remedial Action

- 1) Check that the XTE data displayed on the instrument system is stable, accurate and updating regularly.
- 2) Check the operation of the position fixer, if the device no longer has a position fix it is likely that the NMEA output has stopped. Refer to the troubleshooting guide in your position fixer documentation for further information.

Fault 109 - No (or Low) Wind Speed

Fault Description

There is no valid wind data being received via the instrument system network, or the wind speed is less than 1 kt.

Do not use wind steering modes in very low wind speeds as they are likely to cause erratic steering as the Pilot attempts to follow the changes in wind direction.

Remedial Action

- 1) Check the Measured Wind Speed (MWS) data displayed on the instrument system, if this is very low, and there is obviously a significant amount of wind, investigate the wind instrument wiring connections.
- 2) Check connections to instrument system.

Fault 110 - No Optimum Wind Data

Fault Description

No Optimum Wind Angle data is being received via the Fastnet network.

Remedial Action

- 1) Check the Optimum Wind Angle (OPT W/A) data displayed on the instrument system.
- 2) Check connections to instrument system.

Fault 111 - Current Trip: Drive or Clutch

Fault Description

The current limiting circuit for the drive motor (25A on ACP1, 40A on ACP2) or the clutch (2A) has tripped.

Remedial Action

- 1) Check the installation and wiring for short circuits or loose connections.
- 2) Check the current to the clutch, if this exceeds the maximum value the fault will occur immediately.
- 3) Check the current to the drive motor, if this exceeds the maximum value the fault will occur immediately.

Fault 112 - Network Communication Error

Fault Description

No regular messages are being received by the Pilot computer from the GPD via the Fastnet network, either the display is not transmitting messages or the Pilot computer is not receiving them.

Remedial Action

- 1) Check the installation and operation of the Pilot display.
- 2) If Pilot responds to commands from other displays then the Pilot computer is operating correctly. Check installation of Fastnet network cable.

Fault 113 – Memory Card Changed: Reset End Stops

Fault Description

The memory card fitted is new or from another Pilot and the rudder end-stops are no longer valid.

Remedial Action

Either reset and re-commission the Pilot or, if you are certain the memory card has come from a Pilot of the same software version, carry out the Dockside Commissioning procedure to set the new rudder end stops.

Fault 114 – Memory Card Error

Fault Description

Either the contents of the memory card fitted are not compatible with the Pilot, the memory card is faulty or no card is present.

Remedial Action

- 1) Reset and re-commission the Pilot.
- 2) If a reset is unsuccessful it may be necessary to replace the Pilot memory card, consult your local dealer.

Fault 115 – Drive Power Failure: Check Supply

Fault Description

The Pilot processor PCB is unable to communicate with the drive PCB.

Remedial Action

Check to ensure the high current drive supply is present and is of the correct voltage. It is normal for the drive supply to be on a separate circuit breaker to the rest of the Pilot electronics, ensure this breaker (if present) is switched on.

Pilot Display Shows "NO PILOT"

Fault Description

No regular messages are being received by the Pilot display (GPD) from the Pilot computer via the Fastnet network, either the display is not receiving messages or the Pilot computer is not transmitting them.

Remedial Action

If other displays show Pilot data, check the Fastnet network installation of the affected Pilot display. If the installation is correct suspect a fault with the Pilot display unit.

If no Pilot data is available on any display check the installation of the whole Fastnet network, if there is an instrument system operating on the same network is that data available on displays? If the installation is correct, and the instrument system displays are functioning on the same network, suspect a fault with the Pilot computer.

Pilot Does Not Steer in a Straight Line

Fault Description

The Pilot seems unable to steer straight, it continually overcorrects course errors; the wake has an "S" like appearance as the boat first steers several degrees off course to port followed by several degrees off course to starboard.

Remedial Action

- 1) Drive unit: check for any slack or backlash in the drive system, see earlier section. For steering systems using hydraulics ensure that there is no air in the system.
- 2) Rudder reference sensor: check for any slack or backlash in the assembly and associated linkages, see earlier section.
- 3) Boat speed: check that the boat speed is operating correctly, if you are using a manual boat speed ensure that it is realistic - low boat speed values use more rudder movement.
- 4) Settings: read the commissioning section of the manual carefully and check that the settings in use are appropriate for the type of boat.
- 5) Rudder gain: make large course changes using the pilot, if the gain value is correct the rate of turn should be between 6 and 8 degrees per second. Adjust if necessary, see page 60
- 6) Boat lag: a boat lag value that is too small for the boat can cause instability, try increasing the value slightly, see page 60

Important Note

When dealing with any hydraulic system great care must be taken to ensure that a high degree of cleanliness is observed and no dirt, moisture or foreign objects are allowed to enter the system. Only the recommended fluids must be used. Use Q8 DYNOBEAR or equivalent (10cSt at 40° C).

Drain the steering system from the lowest point, usually at a cylinder coupling.

Fit T-pieces into the port and starboard delivery lines, couple the lines to the appropriate service ports of the pump using flexible hydraulic hose.

Couple the reservoir port to the reservoir/balance line from the helm units. A low pressure, transparent plastic tube can be used. Ensure that this line rises gradually with no down turns.

Refill the steering system as recommended by the manufacturer, using clean hydraulic fluid.

Fill the cylinder by temporarily removing the cylinder couplings and hoses at each end, refit the hoses securely.

Starting at the highest helm unit, fill the helm reservoir.

Slowly turn the steering wheel two turns to port and then to starboard, checking the level of fluid in the helm unit reservoir at all times.

Next, turn the wheel fully in one direction until a slight pressure is felt, continuously monitor the reservoir level.

Repeat in the opposite direction and continue in this manner until topping up is no longer necessary.

When satisfied that the steering is fully bled manually, apply power to the pump unit.

Turning the wheel fully from lock to lock will cause the pump to self-purge.

Check the fluid level in the helm unit reservoir.

When the system appears to be fully functional, with the pump running and the helm hard over check for leaks.

Secure all hoses and cables to prevent damage.

Single Station System Example

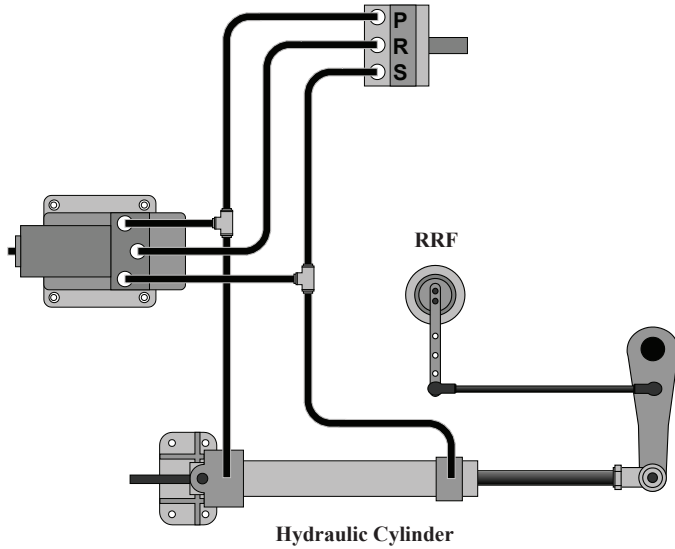

Dual Station System Example

